



WARNING! 

- Carefully read the manual before the installation or use.
- This equipment is to be installed by qualified personnel, complying to current standards, to avoid damages or safety hazards.
- Before any service work on the device, remove all the voltages from measuring and supply inputs and short-circuit the CT input terminals.
- The manufacturer cannot be held responsible for electrical safety in case of improper use of the equipment.
- Products illustrated herein are subject to alteration and changes without prior notice. Technical data and descriptions in the documentation are accurate, to the best of our knowledge, but no liabilities for errors, omissions or contingencies arising there from are accepted.
- A circuit breaker must be included in the electrical installation of the building. It must be installed close by the equipment and within easy reach of the operator. It must be marked as the disconnecting device of the equipment: IEC/EN/BS 61010-1 § 6.11.3.1.
- Clean the device with a soft dry cloth; do not use abrasive products, liquid detergents or solvents.

| INDEX | Page |
|--|------|
| Manual revision history | 1 |
| Introduction | 2 |
| Description | 2 |
| Keyboard functions | 2 |
| Front LED indication | 2 |
| First power-up | 2 |
| Operating modes | 3 |
| Main menu | 3 |
| Password access | 3 |
| Display page navigation | 4 |
| Table of display pages | 4 |
| Harmonic analysis page | 5 |
| Waveform page | 6 |
| Expandability | 6 |
| Additional resources | 7 |
| Communication channels | 7 |
| Modem GSM - GPRS | 7 |
| Inputs, outputs, internal variables, counters, analog inputs | 8 |
| Limit thresholds | 8 |
| Remote-controlled variables | 9 |
| User alarms | 9 |
| Master-Slave configuration | 9 |
| Power factor correction by single phase - SPPFC | 10 |
| IR programming port | 11 |
| Parameter setting through PC | 11 |
| Parameter setting (setup) from front panel | 11 |
| Parameter tables | 12 |
| Output functions table | 16 |
| Input functions table | 16 |
| Alarms | 21 |
| Alarm description | 21 |
| Alarm properties | 21 |
| Alarm property table | 22 |
| Commands menu | 22 |
| Measurement table for limit thresholds and analog outputs | 23 |
| Wiring diagrams | 25 |
| Terminal arrangement | 31 |
| Installation | 31 |
| Mechanical dimensions and panel cutout | 31 |
| Technical characteristics | 32 |

INTRODUCTION

The DCRG8 and DCRG8IND automatic power factor controllers have been design incorporating the state of the art in the functions required for power phase correction applications. Made with a dedicated housing of extremely compact dimensions, DCRG8 and DCRG8IND combine a modern front panel design with practical fitting and the possibility of expansion at the back, where modules of the EXP series can be housed. The LCD graphic display permits a clear and intuitive user interface.

DESCRIPTION

- Automatic power factor controller with 8 built-in relays for capacitor steps, expandable to 24 relays (steps)
- 128x80 pixel, backlit, LCD screen with 4 levels of grey
- 5 navigation keys for functions and settings
- Red LED indication for alarm or abnormal status
- 10-language text for measurements, settings and messages
- Expansion bus with 4 slots for EXP series expansion modules:
 - RS232, RS485, USB, Ethernet, Profibus, GSM/GPRS communications interface
 - Additional digital I/O, static or relay outputs
 - Additional analog I/O for temperature PT100, current, voltage
- Capability to operate with several units interconnected in Master-Slave mode:
 - Maximum configuration: Master + 8 slaves
 - Maximum 32 steps in total
 - Maximum 18 steps per unit
 - Max. 16 static outputs per unit.
 - Max. 24 mixed steps (relay + static).
 - Steps can be paralleled
- Advanced programmable I/O functions
- Fully user-definable alarms
- High accuracy TRMS measurements
- 3-phase + neutral mains voltage measuring inputs
- 3-phase current measuring inputs
- Front optical programming interface: galvanically isolated, high speed, waterproof, USB and WiFi compatible
- Calendar-clock (RTC) with reserve energy
- Storage of last 250 events.

1340 GB 02 21

FRONT KEYBOARD

- Key **✓** - Used to call up the main menu and to confirm a choice.
- Keys **▲** and **▼** - Used to scroll through the display pages or to select the list of options in a menu.
- Key **◀** - Used to decrease a setting / selection or to exit a menu.
- Key **▶** - Used to scroll through any sub-pages or to increase a setting.

FRONT LEDs

Alarm LED (red) – Flashing indicates an active alarm.

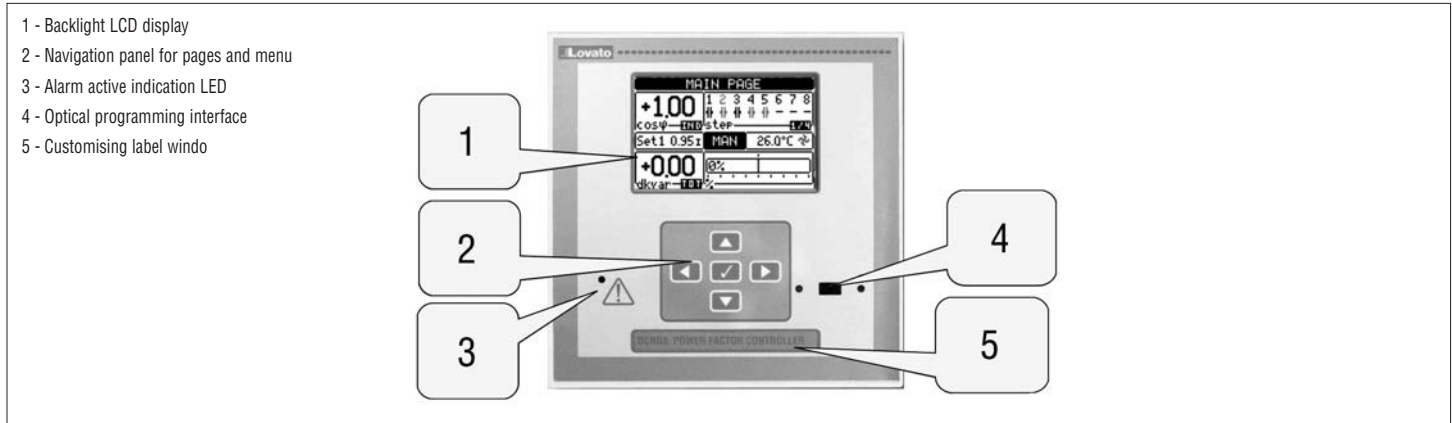

FIRST POWER-UP

- At the first power-up, the controller may ask the user to set the clock-calendar (RTC), in case it is not operational.
- Then a window will appear asking to specify the language you want to use for display navigation. Press OK (✓) for direct access to the parameter P01.01 for the selection of the language.

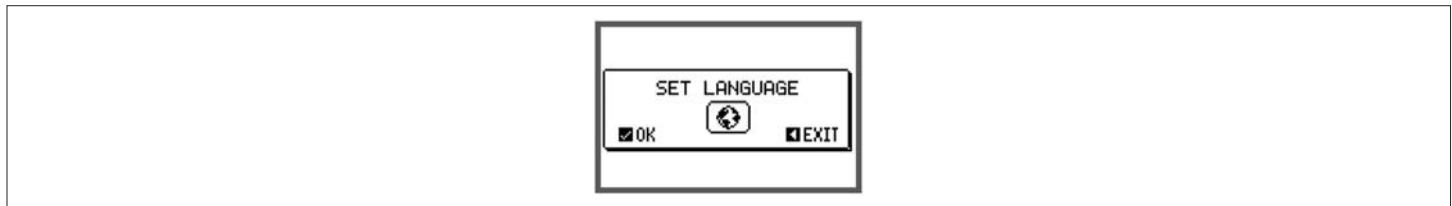

- Another window will then be displayed, prompting you to set the CT primary winding, something usually referred to the installer or end user. Even in this case, it activates a direct access to the setting of the relevant parameter P02.01.



- The above-given procedure will be repeated every time the device is powered up until the CT primary value is set in parameter P02.01.

OPERATING MODES

The correctly selected mode is displayed in reverse at the centre of the home page. There are three possible operating modes, listed below:

TEST Mode

- When the controller is brand new and has never been programmed, it automatically enters in TEST mode that allows the installer to manually activate the individual relay outputs, so the correct wiring of the panel can be checked.
- The activation and deactivation of the outputs are done as per manual mode, but without considering the reconnection time.
- Once in programming and with parameters set, the controller automatically exits the test mode.
- If you need to enter TEST mode after programming the unit, use the appropriate command in the commands menu.

MAN Mode

- When the controller is in manual mode, you can select one of the steps and manually connect or disconnect it.
- From the main page, press ►. Step No. 1 is highlighted by a box. To select the step you want, press ◀ or ►.
- Press ▲ to connect or ▼ to disconnect the selected step.
- If the number above the step is light grey, it means the step is not available because its reconnection time has not elapsed yet. In this case, by sending a close command, the step number will flash to indicate that the operation has been confirmed and will be conducted as soon as possible.
- The manual configuration of steps is maintained even in the absence of supply voltage. When power returns, the original state of the steps is restored.

AUT Mode

- In automatic mode, the controller calculates the optimum configuration of capacitor steps in order to reach the set $\cos\phi$.
- The selection criteria takes into account many variables such as: the power rating of each step, the number of operations, the total time of use, the reconnection time, etc.
- The controller displays the imminent connection or disconnection of the steps by flashing (above) their identification number. The flashing can be prolonged when the insertion of a step is not possible due to the reconnection time (discharge time of the capacitor).
- If the number above the step is light grey, this means the step is not available because its reconnection time is not elapsed yet. The device then waits for the end of the reconnection time.

MAIN MENU

- The main menu is made up of a group of graphic icons (shortcuts) that allow rapid access to measurements and settings.
- Starting from normal measurement viewing, by pressing ✓ the main menu screen is displayed.
- Press ▲ or ▼ to scroll clockwise or counter clockwise to select the required function. The selected icon is highlighted and the central part of the display shows the description of the function.
- Press ✓ to activate the selected function.
- If some functions are not available, the corresponding icon will be disabled, that is shown in a light grey colour.

- etc. - Shortcuts that allow jumping to the first page of that group. Starting from that page, it is still possible to move forward or backward in the usual way.
- - Change the operation to manual or automatic mode.
- - Opens the password entry page, where it is possible to specify the numeric codes that unlock protected functions (parameter setting, commands menu).
- - Access point to the setup menu for parameter programming. See dedicated chapter.
- - Access point to the commands menu, where the authorised user can execute some clearing-restoring actions.

- 1 - Main page
- 2 - Switch to manual mode
- 3 - Switch to automatic mode
- 4 - Voltage – current page
- 5 - Event Log
- 6 - Power page
- 7 - Step life statistics
- 8 - Harmonics
- 9 - System information page
- 10 - Setup menu
- 11 - Commands menu
- 12 - Password entry

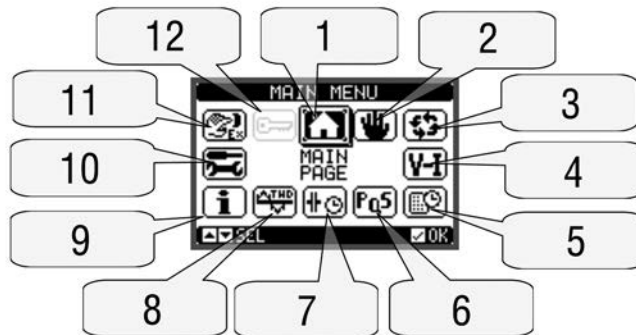

PASSWORD ACCESS

- The password is used to enable or lock the access to setting menu (setup) and to commands menu.
- For brand-new devices (factory default), the password management is disabled and the access is free. If instead, the passwords have been enabled and defined, then to get access, it is necessary to enter the password first, specifying the numeric code through the keypad.
- To enable password management and to define numeric codes, see setup menu M15 Password.
 - **User level access** – Allows clearing of stored values and the editing of a restricted number of setup parameters.
 - **Advanced level access** – Same rights of the user access plus full setup editing-restoring.
- From normal measurement viewing, press ✓ to recall the main menu, then select the password icon and press ✓.
- The display shows the screen illustrated below:



- Keys ▲ and ▼ change the selected digit
- Keys ◀ and ▶ move through the digits.
- Enter all the digits of the numeric code, then move on the key icon.
- If the password code entered matches the User access code or the Advanced access code, then the corresponding unlocked message is shown.
- Once the password is unlocked, the access rights last until:
 - The device is powered off.
 - The device is reset (after quitting the setup menu).
 - The timeout period of two minutes elapses without any keystroke.
- To quit the password entry screen, press ✓ key.

FRONT BUTTON LOCK

The front buttons can be locked to prevent involuntary access to the pages of DCRG8 and DCRG8IND. To enable the button lock, go to the main page and then, holding down the ◀ button, press the ▲ button three times then the ▼ button twice. A pop-up window will appear on the display to indicate that the buttons are locked. Follow the same procedure to unlock.

DISPLAY PAGE NAVIGATION

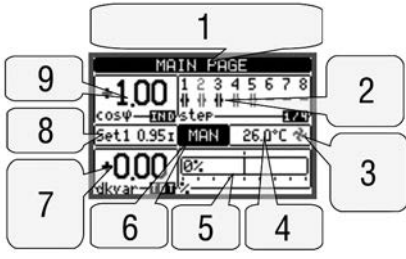
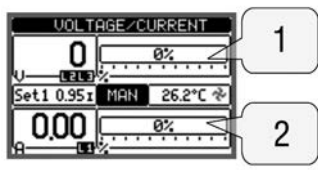
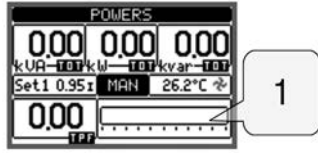
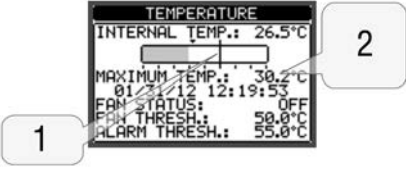
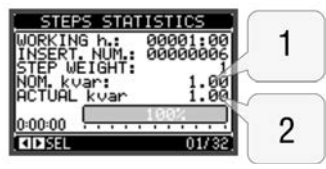
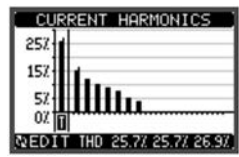
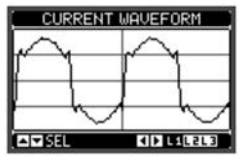

- Keys ▲ and ▼ scroll through the measurements pages one by one. The title bar shows the current page.
- Some measurements may not be shown depending on the controller programming and connections.
- Sub-pages, which can be opened with key ▶, are also available on some pages (for instance displaying voltages and currents in the form of bar graphs).
- The user can specify which page and which sub-page the display should return to automatically when no keys have been pressed for a certain time.
- The controller can also be programmed so that the measurements last displayed remain visible.
- You can set these functions in menu M01 – Utility.

TABLE OF DISPLAY PAGES

| PAGES | EXAMPLE |
|----------------------|--|
| Main page (Home) | <p>1 - Page Title. If P01.09 is set, then the plant description will be shown here.</p> <p>2 - Step status: Black = On Grey = Off</p> <p>3 - Fan status: Black = On Grey = Off</p> <p>4 - Panel temperature</p> <p>5 - kvar bar graph</p> <p>6 - Aut/Man Mode</p> <p>7 - kvar needed to reach setpoint</p> <p>8 - Cosphi setpoint</p> <p>9 - Current Cosphi</p>  |
| Voltage and current | <p>1 - Bar graph referred to rated voltage</p> <p>2 - Bar graph referred to rated current</p>  |
| Power | <p>1 - Bar graph referred to TPF = 1.00</p>  |
| Temperature | <p>1 - Alarm threshold</p> <p>2 - Max temperature peak with time stamp</p>  |
| Step life statistics | <p>1 - Set power</p> <p>2 - Measured power</p>  |
| Harmonics |  |
| Waveforms |  |

1340 GB 02 21

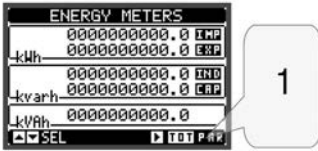
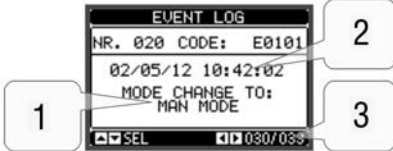
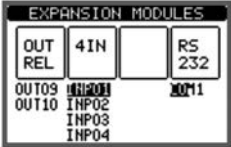
1340_GB_02_21

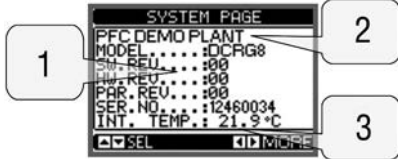
| PAGES | EXAMPLE |
|--------------------|--|
| Energy meters | <p>1 - Key ► switches between Total/Partial indications</p>  |
| Event log | <p>1 - Event description 2 - Event time stamp 3 - Event number / total</p>  |
| Expansion status |  |
| Real time clock |  |
| System information | <p>1 - Level of revision for: Software, Hardware, Parameters 2 - Plant / board name 3 - Internal temperature of panel/controller</p>  |

Note: Some of the pages listed above may not be displayed if the relevant function is disabled. For example, if the limit function is not programmed, the corresponding page will not be shown.

HARMONIC ANALYSIS PAGE

- FFT harmonic analysis calculation and display up to the 31st order for the following measurements can be enabled:
 - Phase-to-phase voltages
 - Phase-to-neutral voltages
 - Currents.
- For each of these measurements, there is a display page that graphically represents the harmonic content (spectrum) with a bar graph.
- Every column is related to one harmonic order, even and odd. The first column shows the total harmonic distortion (THD).
- Every histogram bar is then divided into three parts, one for each phase L1, L2, L3.
- The value of the harmonic content is expressed as a percentage with respect to the fundamental (system frequency).
- It is possible to show the harmonic content in numeric format, selecting the required order using ◀ and ▶. The lower part of the screen will display a small arrow that points to the selected column and the relative percentage value of the three phases.
- The vertical scale of the graph is automatically selected among four full-scale values, depending on the column with the highest value.

1 - Numeric values of the selected order

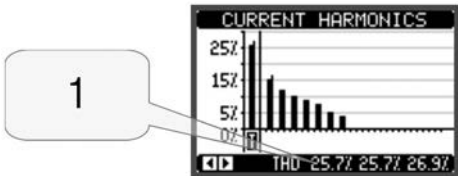

WAVEFORM PAGE

- This page graphically represents the waveform for the voltage and current signals read by DCRG and DCRG8IND.
- It is possible to see one phase at a time, selecting it with ▲ and ▼ keys.
- The vertical scale (amplitude) is automatically scaled in order to fit the waveform on the screen in the best possible way.
- The horizontal axis (time) shows two consecutive periods of the waveform viewed.
- The graph is automatically updated about every second.

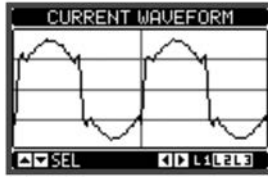

EXPANDABILITY

- Thanks to the expansion bus, DCRG8 and DCRG8IND can be expanded with additional modules of the EXP series.
- It is possible to connect a maximum of 4 EXP... modules at the same time.
- The EXP... modules supported by DCRG8 and DCRG8IND are divided into the following categories:
 - Additional steps
 - Communication modules
 - Digital I/O modules
 - Analog I/O modules.
- To insert an expansion module:
 - Remove power from DCRG8 or DCRG8IND.
 - Remove the protection cover of one of the expansion slots.
 - Insert the upper hook of the module into the fixing slit on the upper end of the expansion slot.
 - Rotate the module downwards, inserting the connector on the bus.
 - Push until the bottom clip snaps in place.

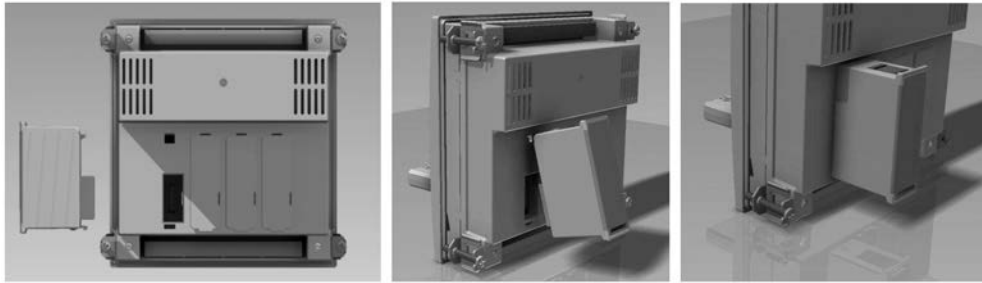

- When DCRG8 or DCRG8IND are powered, they automatically recognise the EXP... modules connected to them.
- If the system configuration has changed with respect to the last saved, (one module has been added or removed), the base unit asks the user to confirm the new configuration. In case of confirmation, the new configuration will be saved and becomes effective, otherwise the mismatch will be shown at every subsequent power-up of the system.

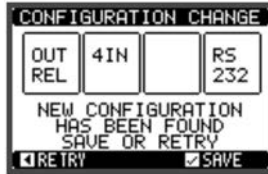

- The current system configuration is shown in the dedicated page of the display (expansion modules), where it is possible to see the number, the type and the status of the modules.
- The I/O numbering is shown under each module.
- The status (energised/de-energised) of every single I/O and communication channel is highlighted in reverse.

- 1 - Type of expansion modules
- 2 - Number and state of additional resources
In reverse = active

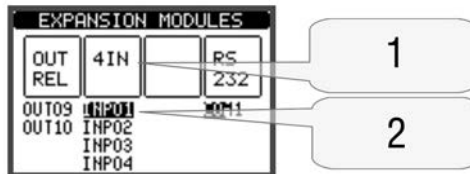

ADDITIONAL RESOURCES

- The expansion modules provide additional resources that can be used through the dedicated setup menus.
- The setup menus related to the expansions are always accessible, even if the expansion modules are not physically fitted.
- Since it is possible to add more than one module of the same type (for instance two communication interfaces), the setup menus are multiple, identified by a sequential number.
- The following table indicates how many modules of each group can be mounted at the same time. The total number of modules must be less than or equal to 4.

| MODULE TYPE | CODE | FUNCTION | Rev. FW DCRG8 | Rev. FW DCRG8IND | MAX N° | SLOT POS. |
|------------------|---------|--|---------------|------------------|-------------------|-----------|
| ADDITIONAL STEPS | EXP1001 | 4 STATIC OUTPUTS (FAST STEP) | ≥ 07 | ≥ 00 | 2 ≤ 06; 4 ≥ 07 | Any |
| | EXP1006 | 2 RELAY OUTPUTS (STEP) | ≥ 00 | ≥ 00 | 4 | Any |
| | EXP1007 | 3 RELAY OUTPUTS (STEP) | ≥ 07 | ≥ 00 | 2 | 1 or 2 |
| COMMUNICATION | EXP1010 | USB | ≥ 00 | ≥ 00 | 2 | Any |
| | EXP1011 | RS232 | ≥ 00 | ≥ 00 | 2 | Any |
| | EXP1012 | RS485 | ≥ 00 | ≥ 00 | 2 | Any |
| | EXP1013 | Ethernet | ≥ 00 | ≥ 00 | 1 | Any |
| | EXP1014 | Profibus® DP | ≥ 07 | ≥ 00 | 1 | Any |
| | EXP1015 | GSM-GPRS (without antenna ^❶) | ≥ 04 | ≥ 00 | 1 | 2 |
| INPUTS/OUTPUTS | EXP1000 | 4 DIGITAL IN | ≥ 00 | ≥ 00 | 2 | 1 or 2 |
| | EXP1002 | 2 DIGITAL IN + 2 STATIC OUT | ≥ 00 | ≥ 00 | 4 | 1 or 2 |
| | EXP1003 | 2 RELAY OUTPUTS | ≥ 00 | ≥ 00 | 4 | Any |
| | EXP1004 | 2 ANALOGUE IN | ≥ 00 | ≥ 00 | 2 | 1 or 2 |
| | EXP1005 | 2 ANALOGUE OUT | ≥ 00 | ≥ 00 | 2 | 1 or 2 |
| | EXP1008 | 2 DIGITAL IN + 2 RELAY OUTPUTS | ≥ 07 | ≥ 00 | 2 | 1 or 2 |
| OTHER FUNCTIONS | EXP1016 | HARMONIC CAPACITOR PROTECTION (current/temp. measurements) | ≥ 02 | ≥ 00 | 4 | Any |
| | EXP1030 | DATA MEMORY + RTC (w/reserve energy) | ≥ 07 | ≥ 00 | 1 | 1 |

❶ Antenna code CX03 is available and can be purchased separately.

❶ Antenna code CX03 is available and can be purchased separately.

COMMUNICATION CHANNELS

- The DCRG8 supports a maximum of 2 communication modules, indicated as COMn. The communication setup menu is thus divided into two sections (n=1 ... 2) of parameters for the setting of the ports.
- The communication channels are completely independent, both for hardware (physical interface) and communication protocol.
- The two channels can communicate at the same time.
- By activating the Gateway function, it is possible to have a DCRG8/DCRG8IND equipped with an Ethernet port and a RS485 port which works as a "bridge" towards the other DCRGs provided with the RS485 port only, and so obtain a saving (one Ethernet access point only).
- In this network, the DCRG with Ethernet port will have parameter P16.n.09 Channel function set to Gateway for both communication channels (COM1, COM2) while the other DCRGs maintain standard configuration with default value = Slave.

GSM - GPRS MODEM

- On the DCRG8 expansion bus it is possible to insert the GSM/GPRS modem module EXP 10 15.
- This module allows to greatly simplify the use of a modem compared to the traditional solution with an external module as it provides the advantages listed below:
- Quadri-band GSM-GPRS modem, suitable for use in with worldwide networks.
- Built-in SIM card holder.
- SMA connector for quad-band outdoor antenna, anti-vandal, IP65 waterproof (Lovato code CX03).

The supported features are summarized below:

- Online connection (CSD-PSD)
Allows you to connect online via the remote control software, in response to an incoming call from your PC or proveninete calling themselves a PC on hold.
- Send SMS with alarms / states / events
Sending states and alarms via SMS to multiple recipients. And 'necessary in this case to specify the phone numbers of the recipients and the conditions that generate the call.
- E-mail sending
As with SMS, but sent to an e-mail account.
- Receiving SMS commands
Allows you to control the DCRG8 by sending an SMS. The supported commands, which can be concatenated into a single message, are the following:

| COMMAND | ACTION |
|---------------------|---|
| MAN, AUT | Change operating mode according to the command |
| STPxx=0, STPxx=1 | Allow you to activate/deactivate a step, where xx is the relevant number of the step (xx=1...32) |
| REMxx=0 REMxx=1 | Allow you to activate/deactivate remote variable REMxx, where xx is the relevant number of the variable (xx=1...10) |
| TIME=ss | Wait ss seconds before executing the following commands |
| INFO? | Ask for general status of the controller. The answer will be a string like the following: ID=DEMO; OM=MAN; MV=411V,413V,412; GV=000V,000V,000V; LC=0000A,0000A,0000A, MC1,GCO; GF=00.0Hz |
| ALARMS? | Ask for the actual alarms status. |

- Sending data and event files on remote FTP server
- It is possible to send all the events recorded by the DCRG8F on a file managed from an FTP server. In this way you can have on the server the updated history of what has happened on all controller in the field.
- The settings required for the operation of the GSM modem can be made through the appropriate Modem parameters window of the remote control software Xpress.
- When the modem is operating into the base unit it is possible to see its status through a dedicated page, that shows the modem action in progress, the signal quality, and eventually the connection problem codes.

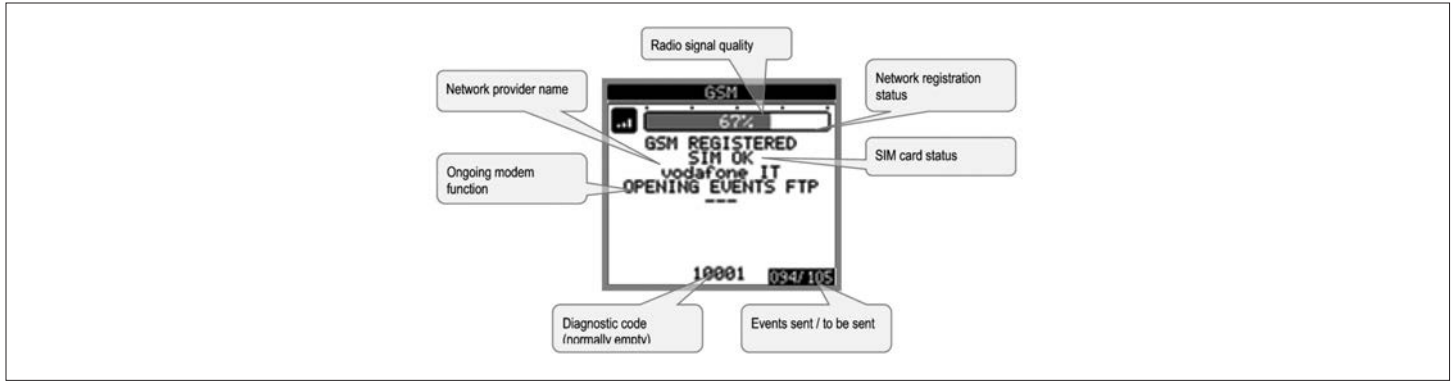

INPUTS, OUTPUTS, INTERNAL VARIABLES, COUNTERS, ANALOG INPUTS

- The inputs and outputs are identified by a code and a sequence number. For instance, the digital inputs are identified by code INPx, where x is the number of the input. In the same way, digital outputs are identified by code OUTx.
- The sequence number of I/Os is simply based on their mounting position, with a progressive numbering from left to right.
- It is possible to manage up to 8 analog inputs (AINx), connected to external analog sensors (temperature, pressure, flow, etc.). The value read by the sensors can be scaled to any unit of measure, viewed on the display and transmitted on the communication bus. The values read by analog inputs are shown on the dedicated display page. They can be used to drive limit thresholds LIMx that can be linked to an internal or external output.
- The expansion I/O numbering starts from the last I/O installed on the base unit. For example, with OUT1...OUT8 digital outputs on the base unit, the first digital output on the expansion modules will be OUT9. See the following table for the I/O numbering:

| CODE | DESCRIPTION | BASE | EXP... |
|------|---------------------|-------|--------|
| INPx | Digital Inputs | - | 1...8 |
| OUTx | Digital Outputs | 1...8 | 9...16 |
| COMx | Communication ports | - | 1...2 |
| AINx | Analog Inputs | - | 1...4 |
| AOUx | Analog Outputs | - | 1...4 |

- In a similar way, there are some internal bit-variables (markers) that can be associated to the outputs or combined between them. For instance, it is possible to apply some limit thresholds to the measurements taken by the system (voltage, current, power, etc.). In this case, the internal variable, named LIMx, will be activated when the measurements go out of the limits defined by the user through the dedicated setting menu.
- Furthermore, there are up to 8 counters (CNT1..CNT8) that can count pulses coming from an external source (through a digital input INPx) or the number of times a certain condition has taken place. For instance, defining a limit threshold LIMx as the count source, it will be possible to count how many times one measurement exceeds a certain limit.
- The following table shows all the internal variables managed by DCRG8 and DCRG8IND, with their range highlighted (number of variables per type).

| CODE | DESCRIPTION | RANGE |
|------|-----------------------------|--------|
| LIMx | Limit thresholds | 1...16 |
| REMX | Remote-controlled variables | 1...16 |
| UAX | User alarms | 1...8 |
| PULx | Energy consumption pulses | 1...3 |
| CNTx | Programmable counters | 1...8 |

LIMIT THRESHOLDS (LIMx)

- The LIMn thresholds are internal variables whose status depends on the out-of-limits of one particular measurement set by the user (e.g. total active power higher than 25kW) among all those measured.
- To make the setting of thresholds easier, since the limits can span in a very wide range, each of them can be set using a base number and a multiplier (for example: 25 x 1k = 25000).
- For each LIM, there are two thresholds (upper and lower). The upper threshold must always be set to a value higher than the lower one.
- The meaning of the thresholds depends on the following functions:

Min function: The lower threshold defines the trip point while the upper threshold for reset. The LIM trips when the selected measurement is less than the lower threshold for the programmed delay. When the measured value is higher than the upper setpoint, after the set delay, the LIM status is reset.

Max function: The upper threshold defines the trip point while the lower threshold for reset. The LIM trips when the selected measurement is more than upper threshold for the programmed delay. When the measured value is below the lower setpoint, after the delay, the LIM status is reset.

Max+Min function: Both thresholds are for tripping. When the measured value is less than the lower or more than the upper setpoint, then the LIM will trip after the respective delays. When the measured value returns within the limits, the LIM status will be immediately reset.

- Trip denotes either activation or de-activation of the LIM variable, depending on 'Normal status' setting.
- If the LIMn latch is enabled, the reset can be done only manually using the dedicated command in the commands menu.
- See setup menu M24.

- 1 - Type of measurement
- 2 - Upper threshold
- 3 - Threshold delay
- 4 - Lower threshold
- 5 - Status of the limit
- 6 - Measurement value
- 7 - Function

The screenshot shows the 'LIMIT THRESHOLDS' menu. Callout 1 points to 'U LI-N', callout 2 to '+100.0', callout 3 to '+179.9s', callout 4 to '+119.9 U', callout 5 to 'LIM1 = 0', callout 6 to '+ 40.0', and callout 7 to 'SEL LIM1 1..8'.

REMOTE-CONTROLLED VARIABLES (REMX)

- DCRG8/DCRG8IND can manage up to 16 variables controlled remotely (REM1...REM16).
- These are variables which status can be modified by the user through the communication protocol and that can be used in combination with outputs.
- Example: using a remote variable (REMX) as a source for an output (OUTx), it will be possible to freely energise or de-energise one relay through the supervision software. This would allow the use of DCRG8 and DCRG8IND output relays to control loads, e.g. lighting or other.

USER ALARMS (UAX)

- The user can define a maximum of 8 programmable alarms (UA1...UA8).
- For each alarm, it is possible to define:
 - The source, that is the condition that generates the alarm.
 - The message text, that is displayed when this condition takes place.
 - The alarm properties (just like for standard alarms), that is how the alarm interacts with the control of the power factor correction board.
- The condition that generates the alarm can be, for instance, the overcoming of a threshold. In this case, the source will be one of the limit thresholds LIMx.
- If instead, the alarm must be displayed depending on the status of an external digital input, then the source will be an INPx.
- For every alarm, the user can define a free-text message that is displayed on the alarms page.
- The properties of the user alarms can be defined in the same way as the normal alarms. You can choose whether a certain alarm will disconnect the steps, close the global alarm output, etc. See chapter Alarm properties.
- When several alarms are active at the same time, they are displayed sequentially and their total number is shown on the status bar.
- To clear an alarm programmed with latch, use the dedicated command in the commands menu.
- For alarm programming and definition, refer to setup menu M26.

MASTER-SLAVE CONFIGURATION

- To further extend the flexibility of DCRG8/DCRG8IND, the Master-Slave function has been made available, which for high-powered systems allows a cascaded series of panel to be set up, each with its own controller and corresponding capacitor banks.
- This solution allows to expand the power factor correction system in a modular way whenever there is an increased power requirement in the plant.
- In this configuration, measurements are made only by the first controller (Master) which controls a maximum of 32 logic steps, that are then sent to all the slave devices.
- The slave controllers drive their own steps as indicated by the master, while performing the "local" protections, such as panel or capacitor overtemperature, no-voltage release, harmonic protections, etc.
- The maximum possible configuration is one master with 8 slaves.

Example 1 (Application in parallel):

A system has 8 logic steps for 400 kvar in total. The system is arranged in two panels (master and slave). Each panel has 8 steps of 25 kvar each. The logic steps are programmed as 8 banks of 50 kvar. The first step is mapped on OUT1 both for the master and for slave 1, the same for step 2 on OUT2 for the master and the slave 1, and so on. When step 1 is activated, the first bank both of the master board (25kvar) and of the slave 1 (25 kvar) for a total of 50kvar will result connected. In this case, the parameter P02.07 Smallest step power must be set (on the master) at the resulting value of 50kvar.

Programming of the master:

| PARAMETER | VALUE | DESCRIPTION |
|-----------------------|------------|--|
| P02.07 | 50 | 50 kvar, 25 on the master and 25 on the slave for each step |
| P03.01.01...P03.08.01 | 1 | All 8 logic steps are of 50kvar |
| P04.01.01...P04.08.01 | Step 1...8 | Outputs OUT1...OUT8 of the master are activated by logic steps 1...8 |
| P05.01 | COMx | COM port used for the link |
| P05.02 | Master | Role of master |
| P05.03 | ON | Enable slave 1 |
| P06.01.01...P06.08.01 | Step 1...8 | Outputs OUT1...OUT8 of the slave are activated by logic steps 1...8 |

Programming of slave 1:

| | | |
|--------|--------|----------------|
| P05.02 | Slave1 | Role as slave1 |
|--------|--------|----------------|

Example 2 (Application in series):

A system with 18 steps of 40kvar each is divided into three identical panels, each with 6 steps, 240kvar in total. For each slave panel, the 8 relay outputs of the controller are used as follows: the first six for the steps (OUT1...6), the seventh for the cooling fan (OUT7) and the last for the alarm (OUT8). On the master panel, there will be 18 logic 40kvar steps. The steps from 1 to 6 will be "mapped" on the outputs OUT1...6 of the master, those from 7 to 12 on the outputs OUT1...6 of slave 1 and finally the steps from 13 to 18 on the outputs OUT1...6 of slave 2. In this case, parameter P02.07 Smallest step power will have to be set (on the master) at 40kvar.

Programming of the master:

| PARAMETER | VALUE | DESCRIPTION |
|-----------------------|--------------|--|
| P02.07 | 40 | 40 kvar |
| P03.01.01...P03.18.01 | 1 | All the 18 logic steps are 40kvar |
| P04.01.01...P04.06.01 | Step 1...6 | Outputs OUT1...OUT6 of the master are activated by logic steps 1...6 |
| P04.07.01 | Fan | OUT7 of the master controls cooling fan |
| P04.08.01 | All glb 1 | OUT8 of the master controls global alarm 1 |
| P05.01 | COM1 | Communication port used for the link |
| P05.02 | Master | Role of master |
| P05.03...P05.04 | ON | Enables slave 1 and slave 2 |
| P06.01.01...P06.06.01 | Step 7...12 | Outputs OUT1...OUT6 of slave 1 are activated by logic steps 7...12 |
| P06.07.01 | Fan | OUT7 of slave 1 controls cooling fan |
| P06.08.01 | Glb al 1 | OUT8 of slave 1 controls global alarm 1 |
| P07.01.01...P07.06.01 | Step 13...18 | Outputs OUT1...OUT6 of slave 2 are activated by logic steps 13...18 |
| P07.07.01 | Fan | OUT7 of slave 2 controls cooling fan |
| P07.08.01 | Glb al 1 | OUT8 of slave 2 controls global alarm 1 |

Programming of slave 1:

| | | |
|--------|--------|----------------|
| P05.02 | Slave1 | Role as slave1 |
|--------|--------|----------------|

Programming of slave 2:

| | | |
|--------|--------|----------------|
| P05.02 | Slave2 | Role as slave2 |
|--------|--------|----------------|

- The communication between master and slaves is via an isolated RS485 communication module type EXP1012 for each device; the maximum distance can be 1000m.
- All programming is done on the master controller: setting the type of system, the CT, the logic steps and step pairing between logic and physical outputs of the master and the slave. The program is then automatically extended to the slaves.
- On the slaves, it is necessary to only set the slave role (with parameter P05.02).
- All parameters relating to this function are grouped in menu M05.
- If the communication between master and slave is cut off, the fault is signalled by an alarm and all slave outputs are disconnected.



- To be sensitive to no-voltage release, the slaves must be connected to the line voltage while it is not necessary to connect the current measuring inputs.
- Each slave displays the main power factor correction data sent by the master, with the state of the 32 logic steps of the entire system (in the usual window at the top right) and the states of its local outputs in a window at the bottom.

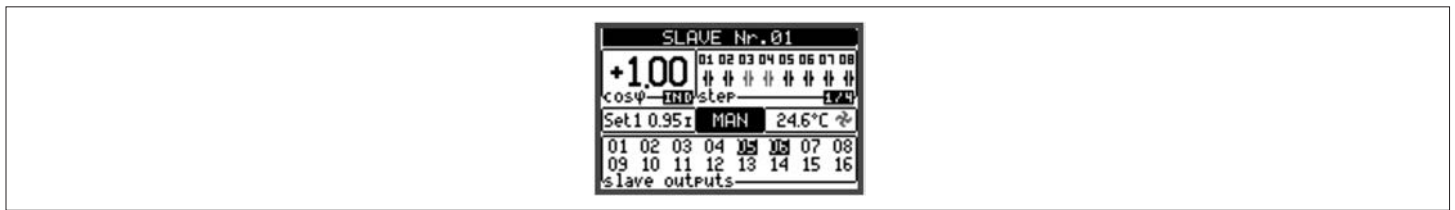

- If there is an alarm in the system that involves all the steps (e.g. lack of current signal, overvoltage, no-voltage release, etc.), all the logic steps are then disconnected that is all the outputs of both the master and the slaves.
- If instead, an alarm occurs that affects only one of the panels (either a master or slave), such as temperature or harmonics protection, then only outputs that control the steps involved in the panel in alarm are de-energised, while the rest of the system continues to work, even if with a limited efficiency.
- Each alarm has a specific property, called Slave disconnection; it indicates if the alarm has implications for the entire system (property set to General) or only on the panel concerned (Local). See the alarms table.

POWER FACTOR CORRECTION BY SINGLE PHASE (SPPFC - Single Phase Power Factor Correction)

- Single phase power factor correction is intended for use in highly unbalanced three-phase systems
- The controller monitors the cosφ of each phase and corrects through a series of single-phase and three-phase capacitor banks.
- For this type of operation, it is important to program the parameters as follows:

P02.03 - Single-phase.

P02.04 - L1 - L2 - L3.

P02.06 - L1 - L2 - L3 - N.

P02.07 - Value in kvar of the smallest step installed (equivalent to weight 1).

P02.08 - Nominal voltage of single-phase capacitor banks.

P03.n.01 - Single-phase steps: Weight of step n, referred to the value of the smallest step set with P02.07.

Three-phase steps: Weight of three-phase step n, referred to the value of the smallest single-phase step set with P02.07 using the following formula: $INT \left[\frac{\text{three-phase step value}}{3 * \text{Value set in parameter P02.07}} \right]$.

Example: with a 60kvar three-phase step and P02.07 = 10 (kvar), $INT = \left[\frac{60}{3 * 10} \right] = 2$. So P03.n.01 is set to 2.

P03.n.03 - Define the type of step (single- or three-phase) and what phase it is connected to. Set L1-L2-L3 for three-phase type bank or L1, L2 or L3 for single-phase banks.

Caution: to activate SPPFC, at least one bank must be connected in single-phase configuration; see example on page 25.

IR PROGRAMMING PORT

- The DCRG8/DCRG8IND parameters may be configured by means of the frontal optical port by means of the IR-USB type CX01 programming dongle or the IR-WiFi type CX02 dongle.
- This programming port has the following advantages:
 - It allows DCRG8 and DCRG8IND configuration and maintenance without requiring access to the back of the device and consequently opening the electrical panel.
 - It is galvanically isolated from the internal DCRG8 and DCRG8IND circuitry, guaranteeing the utmost safety for the operator.
 - High speed data transfer.
 - IP65 front panel protection degree.
 - Limits the possibility of unauthorised access with device configuration.
- Simply hold the CX... dongle in front of the panel and insert the pins on the relevant connectors; the devices will recognise each other as shown by the green colour of the LINK LED on the programming dongle.

1340 GB 02 21



USB programming dongle type CX01

PARAMETER SETTING (SETUP) WITH PC

- Xpress configuration and remote control software can be used to transfer parameters (previously set) from the DCRG8 and DCRG8IND to a PC hard disk and vice versa.
- Parameter transfer from a PC to the DCRG8 and DCRG8IND may be partial, i.e. only the parameters of specified menus will be transferred.
- In addition to the parameter setup, the PC can be used as follows:
 - Logo customising, displayed at power-up and every time you exit keyboard setup.
 - Creating an information page where you can enter application information, characteristics, data, etc.

PARAMETER SETTING (SETUP) FROM FRONT PANEL

- To open the parameters programming menu (setup):
 - Put the device in MAN mode and disconnect all the steps.
 - With measurements page viewed, press ✓ to call up the main menu.
 - Select icon . If it is disabled (displayed in grey), you must enter the password (See chapter Password access).
 - Press ✓ again to open the setup menu.
- The table shown below is displayed, with the setting submenus for all the parameters on the basis of their function.
- Select the required menu with key ▲ or ▼ and confirm with ✓.
- Press ◀ to return to the values view.



Setting: Menu selection

- The following table lists the available submenus:

| CODE | MENU | DESCRIPTION |
|------|---------------------|--|
| M01 | UTILITY | Language, brightness, display pages, etc. |
| M02 | GENERAL | Panel/system data |
| M03 | STEPS | Capacitor step configuration |
| M04 | MASTER OUTPUTS | Programmable outputs of master device |
| M05 | MASTER / SLAVE | Device role (master or slave) |
| M06 | SLAVE1 OUTPUTS | Programmable outputs of slave device 01 |
| ... | ... | |
| M13 | SLAVE8 OUTPUTS | Programmable outputs of slave device 08 |
| M14 | PROG. INPUTS | Programmable digital inputs |
| M15 | PASSWORD | Password access management |
| M16 | COMMUNICATION | Communication channels parameters |
| M17 | BASE PROTECTIONS | Basic protections of the panel |
| M18 | HARMONIC PROTECTION | Harmonic protection available only with EXP1016 module installed |
| M19 | MISCELLANEOUS | Various settings |
| M20 | LIMIT THRESHOLDS | Limit thresholds on measurements |
| M21 | COUNTERS | General programmable counters |
| M22 | ANALOG INPUTS | Programmable analog inputs |
| M23 | ANALOG OUTPUTS | Programmable analog outputs |
| M24 | ENERGY PULSES | Pulses for energy meters increment |
| M25 | USER ALARMS | Programmable user alarms |
| M26 | ALARM PROPERTIES | Actions caused by alarms |

- Select the submenu and press ✓ to show the parameters.
- Each parameter is shown with code, description and current setting value.

- 1 - Parameter code
- 2 - Current setting value
- 3 - Selected parameter
- 4 - Parameter description

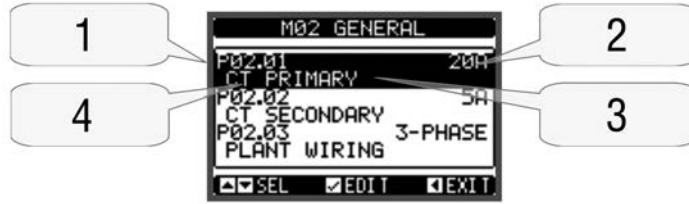

Setting: Parameter selection

- To modify the setting of one parameter, select it and then press ✓.
- If the Advanced level access code has not been entered, it is not possible to enter editing page and an access denied message is shown.
- If instead, the access rights are confirmed, then the editing screen is shown.

- 1 - Selected parameter
- 2 - New value entered
- 3 - Maximum possible setting
- 4 - Factory default setting
- 5 - Graph bar of the value-range
- 6 - Minimum possible setting

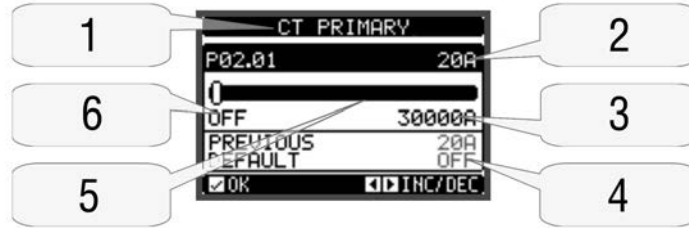

Setting: Page editing

- When the editing screen is displayed, the parameter setting can be modified with ◀ and ▶ keys. The screen shows the new setting while a graphic bar shows the setting range, the maximum and minimum, previous setting and factory default values.
- Pressing ◀ + ▲, the value is set to the minimum possible while with ▲ + ▶, it is set to the maximum.
- Pressing simultaneously ◀ + ▶, the setting is restored to factory default.
- During the entry of a text string, keys ▲ and ▼ are used to select the alphanumeric character while ◀ and ▶ are used to move the cursor along the text string. Pressing keys ▲ and ▼ simultaneously will move the character selection straight to letter "A".
- Press ✓ to go back to the parameter selection. The entered value is stored.
- Press ◀ to save all the settings and to quit the setup menu. The controller executes a reset and returns to normal operation.
- If the user does not press any key for more than 2 minutes, the system leaves the setup automatically and goes back to normal viewing without saving the changes done on parameters.
- Remember that, solely for the setup data that can be edited using the buttons, a backup copy can be made in the DCRG8 and DCRG8IND's EEPROM. This data can be restored, when necessary, in the work memory. The data backup copy and restore commands can be found in the commands menu.

PARAMETER TABLES

- Below are listed all the programming parameters in tabular form. For each parameter, the possible setting range and factory default are indicated as well as a brief explanation of the function of the parameter. The description of the parameter shown on the display can in some cases be different than what is given in the table because of the reduced number of characters available. The parameter code can be used however as a reference.

Note: The parameters highlighted in the table with a grey background are essential for the operation of the system. They therefore represent the minimal essential programming for setting in operation.

| M01 – UTILITY | | UoM | Default | Range |
|---------------|------------------------------------|-----|---------|---|
| P01.01 | Language | | English | English Italian French Spanish Portuguese German Polish Czech Russian Custom |
| P01.02 | Set clock at system power on | | OFF | OFF-ON |
| P01.03 | LCD contrast | % | 50 | 0-100 |
| P01.04 | Display backlight high intensity | % | 100 | 0-100 |
| P01.05 | Display backlight low intensity | % | 25 | 0-50 |
| P01.06 | Time to switch to low backlighting | s | 180 | 5-600 |
| P01.07 | Return to default page | s | 60 | OFF / 10-600 |
| P01.08 | Default page | | main | (page list) |
| P01.09 | System description | | (empty) | String 20 chr. |

- P01.01** – Select display text language.
- P01.02** – Automatic clock setting activation access after power-up.
- P01.03** – LCD contrast adjustment.
- P01.04** – Display backlight high adjustment.
- P01.05** – Display backlight low adjustment.
- P01.06** – Low display backlight delay.
- P01.07** – Default page display restore delay when no key pressed. If set to OFF, the display will always show the last page manually selected.
- P01.08** – Default page displayed at power-up and after delay.
- P01.09** – Free text with alphanumeric identifier name of specific panel/system. If a description is set here, it will be shown as title of the main page. The same description is also used as identification for remote alarm/event reporting via SMS/email.

| M02 - GENERAL | | UoM | Default | Range |
|---------------|---|--------|--------------|--|
| P02.01 | CT primary | A | OFF | OFF/1-30000 |
| P02.02 | CT secondary | A | 5 | 1 / 5 |
| P02.03 | Type of plant installation | | Three-ph | Three-phase Single phase |
| P02.04 | Current reading phase | | L3 | L1 / L2 / L3 / L1-L2-L3 |
| P02.05 | CT polarity | | Aut | Aut - Dir - Rev |
| P02.06 | Voltage reading phase | | L1-L2 | L1-L2 / L2-L3 / L3-L1 / L1-N / L2-N / L3-N / L1-L2-L3 / L1-L2-L3-N |
| P02.07 | Smallest step power | kvar | 1.00 | 0.10 – 10000 |
| P02.08 | Capacitor rated voltage | V | 400 | 50 – 50000 |
| P02.09 | Rated frequency | Hz | Aut | Aut - 50Hz - 60Hz - Variable |
| P02.10 | Reconnection time | s | 60 | 1-30000 |
| P02.11 | Sensitivity | s | 60 | 1-1000 |
| P02.12 | Disconnection sensitivity | s | OFF | OFF / 1 – 600 |
| P02.13 | Setpoint cosphi 1 (standard) | | 0.95 IND | 0.50 IND – 0.50 CAP |
| P02.14 | Setpoint cosphi 2 | | 0.95 IND | 0.50 IND – 0.50 CAP |
| P02.15 | Setpoint cosphi 3 | | 0.95 IND | 0.50 IND – 0.50 CAP |
| P02.16 | Setpoint cosphi generating | | 0.95 IND | 0.50 IND – 0.50 CAP |
| P02.17 | Setpoint + clearance | | 0.00 | 0 – 0.10 |
| P02.18 | Setpoint - clearance | | 0.00 | 0 – 0.10 |
| P02.19 | Step disconnection when generating | | OFF | OFF - ON |
| P02.20 | System rated current | A | Aut | Aut / 1 – 30000 |
| P02.21 | System rated voltage | V | Aut | Aut / 100 – 60000 |
| P02.22 | System voltage type | | LV | LV - LV / MV - MV |
| P02.23 | VT usage | | OFF | OFF - ON |
| P02.24 | VT1 primary | V | 100 | 50-50000 |
| P02.25 | VT1 secondary | V | 100 | 50-500 |
| P02.26 | VT2 primary | V | 100 | 50-50000 |
| P02.27 | VT2 secondary | V | 100 | 50-500 |
| P02.28 | Step insertion mode | | Standard | Standard / Linear Fast / Linear Single / OFF-ON |
| P02.29 | Static switching delay | cycles | 3 | 1-20 |
| P02.30 | Tanphi setpoint enable | | OFF | OFF - ON |
| P02.31 | Tanphi setpoint | | 0 | -1.732 to +1.732 |
| P02.32 | Sensitivity mode | | Proportional | Proportional - Fixed |
| P02.33 | Generation tanφ setpoint | | 0 | -1.732 to +1.732 |
| P02.34 | Angle correction | ° | 0 | 0-359 |
| P02.35 | Correction with inductors (DCRG8IND only) | | MIX | MIX / NO-MIX |

P02.01 – The value of the primary current transformer. Example: with CT 800/5A set 800.

If set to OFF, after the power-up the device will prompt you to set the CT and allow direct access to this parameter.

P02.02 – Value of the secondary of the current transformers. Example: With CT 800/5A, set 5.

P02.04 – Defines on which and on how many phases the device reads the current signal. The wiring of current inputs must match the value set for this parameter. Supports all possible combinations of parameter P02.06.

P02.05 – Reading the connection polarity of the CTs.

Aut = Polarity is automatically detected at power up. It can be used when working with one CT only and when the system has no generator device.

Dir = Automatic detection disabled. Direct connection.

Rev = Automatic detection disabled. Reverse wiring.

P02.06 – Defines on which and on how many phases the device reads the voltage signal.

The wiring of voltage inputs must match the setting for this parameter. Supports all possible combinations of parameter P02.04.

P02.07 – Value in kvar of the smallest step installed (equivalent to the step weight 1). Rated power of the capacitor bank provided at the rated voltage specified in P02.08 and referred to the total of the three capacitors for three-phase applications.

P02.08 – Rated nameplate voltage of capacitors, at which the specified power of P02.07 is supplied. If the capacitors are used at a voltage different (lower) than rated one, the resulting power is automatically recalculated by the device.

P02.09 – Working frequency of the system. **Auto** = Automatic selection between 50 and 60 Hz at power up. **50Hz** = Fixed at 50 Hz. **60Hz** = Fixed to 60 Hz.

Variable = Measured continuously and adjusted.

P02.10 – Minimum time that must elapse between the disconnection of one step and the subsequent reconnection both in MAN and AUT. During this time, the number of the steps on the main page is shown in light grey. Reconnection time = sensitivity/delta kvar * smallest step power.

P02.11 – Connection sensitivity. Parameter that sets the controller reaction speed. With low values, regulation is fast (more accurate around the setpoint but with more step switchings). With high values instead, there are slower regulation reactions with fewer switchings of the steps. The delay time of the reaction is inversely proportional to the request of steps to reach the setpoint: waiting time = (sensitivity / number of steps required).

Example: Setting the sensitivity to 60s, if you require the connection of one step of weight 1, expected time is 60s (60/1 = 60). If instead, a total of 4 steps is needed, expected time is 15s (60/4 = 15).

P02.12 – Disconnection sensitivity. Same as the previous parameter but related to disconnection. If set to OFF, the disconnection has the same reaction time as connection set with the previous parameter.

P02.13 – Setpoint (target value) of the power factor (cosphi). Value used for standard applications.

P02.14 – **P02.15** – Alternative setpoints selectable with combinations of digital inputs programmed with the appropriate function.

P02.16 – Setpoint used when the system is generating active power to the supplier.

P02.17 – **P02.18** – Tolerance around the setpoint. When the cosφ is in the range set by these parameters, in AUT steps are not inserted/removed, even if the kvar-delta is greater than the smallest step.

Note: + means "tends to capacitive", - means "tends to inductive".

P02.19 – If set to ON, when the system is giving active power to the supplier (generation = negative active power and power factor), all steps are disconnected.

P02.20 – Rated current of the system. Value used for the full scale of the bar graphs and for setting the current thresholds, expressed as a percentage.

If set to Aut, then the value of P02.01 (CT primary) is used.

P02.21 – Rated voltage of the system. Value used for the full scale of the bar graphs and setting the voltage thresholds, expressed as a percentage.

If set to Aut, then the value of P02.08 (rated voltage of capacitors) is used.

P02.22 – Type of system voltage. Depending on the setting of this parameter, the appropriate wiring diagrams must be used. See at the end of the manual.

P02.23 ... P02.27 – Data of VTs eventually used in the wiring diagrams.

P02.28 – Selection of step connection mode

Standard = Normal operation with free selection of the steps.

Linear = The steps are connected in progression from left towards right only, following the step number and according to the LIFO (Last In First Out) logic. When the system steps are of different ratings, the controller will not connect a step if the set-point value would be exceeded.

Fast = Fast switching for use with static/thyristor modules and parameter P03.n.02 set to Static.

Linear single = Linear mode in which only one step is inserted at each triggering of the sensitivity irrespective of the total number of steps necessary.

OFF>ON = As standard mode but at each triggering of the sensitivity all steps to be disconnected are removed first and then all steps to be connected are inserted.

P02.29 – After having closed one step output, the measurement acquisition is suspended for the number of periods (cycles) specified by this parameter, in order to allow the external static module to connect the capacitors. This function avoids regulation oscillations. Set this value according to the technical characteristics (closing time) declared by the manufacturer of the static module.

P02.30 – Enables the setting of the setpoint as Tangent of displacement phase angle (Tanphi) instead of Cosine (Cosphi). Used as a reference by the energy providers of some European countries.

P02.31 – Value of the Tanphi setpoint. Negative Tanphi values correspond to capacitive Cosphi.

P02.32 – Sensitivity mode selection:

Proportional = The sensitivity delay time is inversely proportional to the reactive power required.

Fixed = The sensitivity delay time is fixed irrespective of the reactive power required.

P02.33 – $\tan\phi$ setpoint used when the system is granting active power to the supplier (greater precision around the setpoint but greater number of operations).

P02.34 – Angular setpoint for compensating for the phase variation introduced by a transformer between the voltages on the primary winding and those on the secondary winding.

P02.35 – Defines whether, in a system in which compensation is achieved both with capacitors and with inductors, the simultaneous connection of both steps types is permitted or not. MIX = A mixed combination of capacitors and inductors is possible. NON-MIX = Either only capacitors or only inductors are connected, depending on the nature of the load.

| M03 - STEPS (STPn, n=1...32) | | UoM | Default | Range |
|------------------------------|---------------------------|-----|-----------|-------------------------------|
| P03.n.01 | Step weight | | OFF | OFF/ 1 – 99 |
| P03.n.02 | Step insertion type | | Contactor | Contactor / Static / Fixed |
| P03.n.03 | Step phase selection | | L1-L2-L3 | L1-L2-L3 / L1 / L2 / L3 |
| P03.n.04 | Step type (DCRG8IND only) | | CAP | CAP IND |

Note: This menu is divided into 32 sections that refer to 32 possible logic steps STP1...STP32 which can be managed by the DCRG8.

P03.n.01 – Weight of step n, referred to the value of the smallest step. The number that indicates the multiple of the power of the current step with reference to the smallest set at P02.07. If set to OFF, the step is disabled and will not be used.

P03.n.02 – Type of device referred to the switching of the step.

Contactor = Electromechanical switching by contactor. For this step, the reconnection time is used.

Static = Electronic switching by thyristor module. For this step, the reconnection time is not considered. Used for Fast power factor correction.

Fixed = Step always connected. The reactive power for this step is not considered mathematically in the calculation of the power factor correction electrical parameters. This function is typically used to correct the secondary winding of the medium transformer if present.

P03.n.03 – Defines whether the steps are three-phase or single-phase type and what phase the steps are connected to.

P03.n.04 – Defines whether the step in question controls a capacitor or inductor bank. The programming is independent for each step.

- NOTE:
- A free combination of capacitors and inductors can be created. The power of each step is defined as usual, i.e. weight of step multiplied by value of the smallest step.
 - The capacitive and inductive steps are displayed with a specific icon on the main page in order to be able to distinguish them.
 - The inductive steps do not take reconnection time into account.
 - The undercompensation and overcompensation alarm logic takes the status and type of steps inserted into account.

| M04 –MASTER OUTPUTS (OUTn, n=1...16) | | UoM | Default | Range |
|--------------------------------------|-----------------------|-----|--------------------|------------------------------|
| P04.n.01 | Output OUTn function | | n=1...8 Step x | See Output function table |
| | | | n=9...24 OFF | |
| P04.n.02 | Channel number x | | n=1...8 x=1...8 | OFF/1 – 99 |
| | | | n=9...24 x=1 | |
| P04.n.03 | Normal/Reverse output | | NOR | NOR - REV |

Note: This menu is divided into 24 sections, which refer to 24 possible digital outputs OUT01...OUT24 that can be managed by DCRG8/DCRG8IND master, of which OUT01...OUT08 on the basic device and OUT09...OUT24 on any expansion modules.

P04.n.01 – Choice of the function for the selected output (see programmable output function table on page 14).

P04.n.02 – Channel number associated with the function programmed in the previous parameter. Example: If the output function is set to Alarm Axx and you want this output to be energised for alarm A31, then set the value to 31.

P04.n.03 – Sets the state of the output when P04.n.01 is inactive (OFF): **NOR** = Output de-energised; **REV** = Output energised.

| M05 – MASTER / SLAVE | | UoM | Default | Range |
|----------------------|-----------------------|-----|---------|---|
| P05.01 | Master-Slave function | | OFF | OFF COM1 COM2 |
| P05.02 | Device role | | Master | Master Slave01 Slave02 Slave03 ... Slave08 |
| P05.03 | Slave 1 enable | | OFF | OFF-ON |
| P05.04 | Slave 2 enable | | OFF | OFF-ON |
| P05.05 | Slave 3 enable | | OFF | OFF-ON |
| P05.06 | Slave 4 enable | | OFF | OFF-ON |
| P05.07 | Slave 5 enable | | OFF | OFF-ON |
| P05.08 | Slave 6 enable | | OFF | OFF-ON |
| P05.09 | Slave 7 enable | | OFF | OFF-ON |
| P05.10 | Slave 8 enable | | OFF | OFF-ON |

P05.01 – Defines whether the system is used in master-slave configuration or not. With OFF, the system works with a single controller (normal configuration).

If COM1 or COM2 is set, working in master-slave mode, the setting indicates which channel is used to communicate between controllers.

P05.02 – Defines whether the current device is a master or a slave and in this case, which is its number.

P05.03... P05.10 – Enables the operation of individual slaves.

| M06 - SLAVE 01 OUTPUTS (n=1...16) | | UoM | Default | Range |
|-----------------------------------|------------------------|-----|--------------------|------------------------------|
| P06.n.01 | Output OUTn function | | n=1...8 Step x | See Output function table |
| | | | n=9...16 OFF | |
| P06.n.02 | Channel number x | | n=1...8 x=1...8 | OFF/1 – 99 |
| | | | n=9...16 x=1 | |
| P06.n.03 | Output normal/reversed | | NOR | NOR - REV |

Note: This menu is divided into 16 sections, which refer to 16 possible digital outputs **OUT01...OUT16** that can be managed by **DCRG8/DCRG8IND** slave 1, of which **OUT01...OUT08** on the basic device and **OUT09...OUT16** on any expansion modules.

P06.n.01 – Choice of the function for the selected output (see programmable output functions table).

P06.n.02 – Channel number associated with the function programmed in the previous parameter. Example: If the output function is set to Alarm Axx and this output is to be energised for alarm A31, then set the value 31.

P06.n.03 – Sets the state of the output when P06.n.01 is inactive (OFF): **NOR** = Output de-energised; **REV** = Output energised.

| M07 – SLAVE 02 OUTPUTS (n=1...16) | | UoM | Default | Range |
|--|------------------------|-----|--------------------|------------------------------|
| P07.n.01 | Output OUTn function | | n=1...8 Step x | See Output function table |
| | | | n=9...16 OFF | |
| P07.n.02 | Channel number x | | n=1...8 x=1...8 | OFF/1 – 99 |
| | | | n=9...16 x=1 | |
| P07.n.03 | Output normal/reversed | | NOR | NOR - REV |
| As previous menu but referred to slave 02. | | | | |

...

| M13 – SLAVE 08 OUTPUTS (n=1...16) | | UoM | Default | Range |
|--|------------------------|-----|--------------------|------------------------------|
| P13.n.01 | Output OUTn function | | n=1...8 Step x | See Output function table |
| | | | n=9...16 OFF | |
| P13.n.02 | Channel number x | | n=1...8 x=1...8 | OFF/1 – 99 |
| | | | n=9...16 x=1 | |
| P13.n.03 | Output normal/reversed | | NOR | NOR - REV |
| As previous menu but referred to slave 08. | | | | |

OUTPUT FUNCTION TABLE

- The following table shows all the functions that can be attributed to the OUTn programmable digital outputs.
- Each output can be configured so it has a normal or reverse (NOR or REV) function.
- Some functions require another numeric parameter, defined in the channel number x specified by parameter **P04.n.02**.
- Refer to menu M04 Master outputs and M06...M13 Slave outputs for more details.

| FUNCTION | DESCRIPTION |
|----------------------|--|
| OFF | Output always de-energised |
| ON | Output always energised |
| Step x | Capacitor step no.x |
| Global alarm 1 | Energised when global alarm 1 is active |
| Global alarm 2 | Energised when global alarm 2 is active |
| Global alarm 3 | Energised when global alarm 3 is active |
| Fan | Panel ventilation fan |
| Manual mode | Active when the controller is in MAN mode |
| Automatic mode | Active when the controller is in AUT mode |
| Limit threshold LIMx | Output driven by LIM limits (x= 1...16) |
| Pulse PULx | Output driven by PUL pulses (x = 1...6) |
| Remote variable REMx | Output is remotely controlled by REM variable |
| Alarms A01-Axx | When the selected Axx alarm is present, the output is activated (xx= 01... alarm number) |
| Alarms UA1..UAX | When the selected UAX user alarm is present, the output is activated (x=1... 8) |

| M14 – PROGRAMMABLE INPUTS (INPn, n=1...8) | | UoM | Default | Range |
|---|---------------------|-----|---------|-----------------------------|
| P14.n.01 | INPn input function | | OFF | (see Input functions table) |
| P14.n.02 | Channel number x | | OFF | OFF / 1...99 |
| P14.n.03 | Type of contact | | NO | NO/NC |
| P14.n.04 | Delay ON | s | 0.05 | 0.00-600.00 |
| P14.n.05 | Delay OFF | s | 0.05 | 0.00-600.00 |

Note: This menu is divided into 8 sections that refer to 8 possible digital inputs

P14.n.01 – Choice of the function for the selected input (see programmable input functions table).

P14.n.02 – Channel number associated with the function programmed in the previous parameter. If the input function is set to Setpoint selection $\cos\varphi$ x, and this input must select $\cos\varphi$ 3, the value must be set to 3.

P14.n.03 – Select the type of contact: **NO** (Normally Open) or **NC** (Normally Closed).

P14.n.04 – Contact closing delay for selected input.

P14.n.05 – Contact opening delay for selected input.

INPUT FUNCTIONS TABLE

- The following table shows all the functions that can be attributed to the INPn programmable digital inputs.
- Each input can be set for an reverse function (NO - NC), delayed energising or de-energising at independently set times.
- Some functions require another numeric parameter, defined in the channel number x specified by parameter **P14.n.02**.
- Refer to menu M14 Programmable inputs for more details.

| FUNCTION | DESCRIPTION |
|------------------------------|---|
| OFF | Disabled input |
| Configurable | Free user configurable input INPx. Used for instance to generate a user alarm UA or to count on a CNT counter |
| Automatic mode | When active, switches system to AUT mode |
| Manual mode | When active, switches system to MAN mode |
| Select $\cos\phi$ setpoint x | When active, selects the $\cos\phi$ setpoint x (x=1...3) |
| Keyboard lock | Locks front keyboard |
| Settings lock | Locks access to setup menu and commands menu |
| Alarm inhibition | Selectively disables alarms having inhibit property set to ON |
| Key 1 | The input performs the same function of the button "arrow up" ▲ of the frontal keyboard |
| Key 2 | The input performs the same function of the button "right arrow" ► of the frontal keyboard |
| Key 3 | The input performs the same function of the button "arrow down" ▼ of the frontal keyboard |
| Key 4 | The input performs the same function of the button "left arrow" ◀ of the frontal keyboard |
| Key 5 | The input performs the same function of the button "enter" ✓ of the frontal keyboard |

| M15 – PASSWORD | | UoM | Default | Range |
|----------------|-------------------------|-----|---------|------------|
| P15.01 | Enable password | | OFF | OFF-ON |
| P15.02 | User level password | | 1000 | 0-9999 |
| P15.03 | Advanced level password | | 2000 | 0-9999 |
| P15.04 | Remote access password | | OFF | OFF/1-9999 |

P15.01 – If set to OFF, password management is disabled and anyone has access to the settings and commands menu.

P15.02 – With P15.01 enabled, this is the code number to access user level. See Password access chapter.

P15.03 – As per P15.02 but referred to Advanced level access.

P15.04 – If set to a numeric value, this becomes the code to specify via serial communication before sending commands from a remote control site.

| M16 – COMMUNICATION (COMn, n=1...2) | | UoM | Default | Range |
|-------------------------------------|---------------------|-----|-----------------|---|
| P16.n.01 | Node serial address | | 01 | 01-255 |
| P16.n.02 | Serial port speed | bps | 9600 | 1200 2400 4800 9600 19200 38400 57600 115200 |
| P16.n.03 | Data format | | 8 bit – n | 8 bit - no parity (n) 8 bit, odd 8 bit, even 7 bit, odd 7 bit, even |
| P16.n.04 | Stop bits | | 1 | 1-2 |
| P16.n.05 | Protocol | | Modbus RTU | Modbus RTU Modbus ASCII Modbus TCP |
| P16.n.06 | IP address | | 192.168.1.1 | 000.000.000.000 – 255.255.255.255 |
| P16.n.07 | Subnet mask | | 255.255.255.0 | 000.000.000.000 – 255.255.255.255 |
| P16.n.08 | IP port | | 1001 | 0-9999 |
| P16.n.09 | Channel function | | Slave | Slave / Gateway Mirror |
| P16.n.10 | Client / server | | Server | Client / Server |
| P16.n.11 | Remote IP address | | 000.000.000.000 | 000.000.000.000 – 255.255.255.255 |
| P16.n.12 | Remote IP port | | 1001 | 0-9999 |
| P16.n.13 | IP gateway address | | 000.000.000.000 | 000.000.000.000 – 255.255.255.255 |

Note: This menu is divided into 2 sections for communication channels COM1...2.

The front IR communication port has fixed communication parameters, so no setup is required.

P16.n.01 – Serial (node) address of the communication protocol.

P16.n.02 – Communication port transmission speed.

P16.n.03 – Data format. 7 bit settings can be used for ASCII protocol only.

P16.n.04 – Stop bit number.

P16.n.05 – Select communication protocol.

P16.n.06...P16.n.08 – TCP-IP coordinates for Ethernet interface applications. Not used with other types of communication modules.

P16.n.09 – Role of the communication channel. **Slave** = Slave Modbus. **Gateway** = Bridge between the Ethernet and serial ports. **Mirror** = Remote panel mirror (reserved/function not operative yet).

P16.n.10 – Enabling TCP-IP connection. **Server** = Awaits connection from a remote client. **Client** = Establishes a connection to the remote server.

P16.n.11...P16.n.13 – Coordinates for the connection to the remote server when P16.n.10 is set to Client.

| M17 – BASIC PROTECTIONS | | UoM | Default | Range |
|-------------------------|---|-----|-----------------|----------------------------------|
| P17.01 | Temperature unit of measure | | °C | °C / °F |
| P17.02 | Internal panel temperature measurement source | | Internal sensor | Internal sensor / AINx / NTCx |
| P17.03 | Channel number x | | 1 | 1-99 |
| P17.04 | Fan start temperature | ° | 50 | 0-212 |
| P17.05 | Fan stop temperature | ° | 45 | 0-212 |
| P17.06 | Internal panel temperature alarm threshold | ° | 55 | 0-212 |
| P17.07 | Capacitor current overload | | ON | OFF - ON |
| P17.08 | Capacitor current overload threshold | % | 125 | OFF / 100 – 150 |
| P17.09 | Immediate step disconnection threshold | % | 150 | OFF / 100 – 200 |
| P17.10 | Current overload alarm reset time | min | 5 | 1 – 30 |
| P17.11 | Step trimming | | OFF | OFF - ON |
| P17.12 | Faulty step alarm threshold | % | OFF | OFF / 25...100 |
| P17.13 | Maximum voltage threshold | % | 120 | OFF / 90...150 |
| P17.14 | Minimum voltage threshold | % | OFF | OFF / 60...110 |
| P17.15 | Max THDV alarm threshold | % | OFF | OFF/1..250 |
| P17.16 | Max THDI alarm threshold | % | OFF | OFF/1..250 |

P17.02 – Defines which sensor is providing the temperature measurement inside the panel: **Internal sensor** – Sensor built into the controller;

AINx – Temperature by PT100 input on EXP1004 expansion module; **NTCx** – Temperature by NTC input on EXP1016 expansion module.

P17.03 – Channel number, relative to the previous parameter.

P17.04 – P17.05 - Start and stop temperature for the cooling fan of the panel, expressed in the unit set by P17.01. It is also possible to force the fan to start for a time of 30 seconds by going to the dedicated temperature page and holding down the ◀ button for three seconds.

P17.06 – Threshold for alarm generation A07 Panel temperature too high.

P17.07 – Enables the measurement of the capacitor current overload, calculated from the waveform of the applied voltage.

Note: This protection can only be used if the capacitors are not equipped with filtering devices such as inductors or similar.

P17.08 – Trip threshold of capacitor overload protection (alarm A08) triggered after a integral delay time that is inversely proportional to the overload value.

P17.09 – Threshold beyond which the overload tripping integral delay is zeroed, causing the immediate tripping of the protection and alarm.

P17.10 – Delay time for the overload alarm resetting.

P17.11 – Enables the measurement of the actual power of the steps, performed each time they are connected. The measurement is calculated, since the current drawn is referred to the whole load of the installation. The measured power of the steps is adjusted (trimmed) after each switching and is displayed on the step life statistics page.

P17.12 – Percentage threshold of the residual power of the steps, compared with the original power programmed in main menu. Below this threshold, alarm A10 step failure is generated.

P17.13 – Maximum voltage alarm threshold, referred to the rated voltage set with P02.21, above which alarm A06 Voltage too high is generated.

P17.14 – Undervoltage alarm threshold, referred to the rated voltage set with P02.21, below which alarm A05 voltage too low is generated.

P17.15 – Maximum voltage THD threshold, above which alarm A24 – THDV too high is generated.

P17.16 – Maximum current THD threshold, above which alarm A25 – THDI too high is generated.

| M18 – HARMONIC PROTECTION (HARn, n=1...4) | | UoM | Default | Range |
|---|-------------------------------|-----|-----------|---|
| P18.n.01 | CT primary | A | 5 | 1 - 30000 |
| P18.n.02 | CT secondary | A | 5 | 1 / 5 |
| P18.n.03 | CT wiring | | 2 in Aron | 2 in Aron 1 balanced |
| P18.n.04 | Rated current | A | 5 | 1 - 30000 |
| P18.n.05 | CT positioning | | Global | Global Step 1 Step 2 Step 8 |
| P18.n.06 | Current limit | % | OFF | OFF / 100 - 200 |
| P18.n.07 | Current THD Limit | % | OFF | OFF / 1 – 200 |
| P18.n.08 | 5rd Harmonic current limit | % | OFF | OFF / 1 – 200 |
| P18.n.09 | 7th Harmonic current limit | % | OFF | OFF / 1 – 200 |
| P18.n.10 | 11th Harmonic current limit | % | OFF | OFF / 1 – 200 |
| P18.n.11 | 13th Harmonic current limit | % | OFF | OFF / 1 – 200 |
| P18.n.12 | Temperature alarm threshold 1 | ° | 55 | OFF / 1-212 |
| P18.n.13 | Temperature alarm threshold 2 | ° | 55 | OFF / 1-212 |

Note: Parameters in this menu are referred to protections that are available only when using the harmonic protection module EXP1016.

P18.n.01 – P18.n.02 – CT primary and secondary values used for current measurement in power factor correction panel and connected to the harmonic protection module.

P18.n.03 – Current measurement wiring mode:

2 in Aron – Reading of three currents (3-phase) with two CT in Aron configuration.

1 balanced – Reading of a single current with the single CT.

P18.n.04 – Rated current flowing in the power factor correction branch under normal conditions.

P18.n.05 – Branch of the circuit where measuring CTs are located for harmonic protection.

P18.n.06 – Max current threshold in the power factor correction branch, used to generate alarm A11.

P18.n.07 – Current THD maximum threshold in the power factor correction branch and used to generate alarm A12.

P18.n.08 – 5th harmonic content threshold in the power factor correction branch and used to generate alarm A13.

P18.n.09 – 7th harmonic content threshold in the power factor correction branch and used to generate alarm A14.

P18.n.10 – 11th harmonic content threshold in the power factor correction branch and used to generate alarm A15.

P18.n.11 – 13th harmonic content threshold in the power factor correction branch and used to generate alarm A16.

P18.n.12 – P18.n.13 – Maximum temperature thresholds on sensors NTC 1 and 2 (e.g. type NTC01) connected to the harmonic protection module. Used to generate alarms A17 and A18.

| M19 - MISCELLANEOUS | | UoM | Default | Range |
|---------------------|---|------|------------|--------------------------|
| P19.01 | Disconnection of steps when switching to MAN mode | | OFF | OFF/ON |
| P19.02 | Maintenance interval 1 | h | 9000 | 1 - 30000 |
| P19.03 | Maintenance mode 1 | | Always | Always Step inserted |
| P19.04 | Maintenance interval 2 | h | 9000 | 1 - 30000 |
| P19.05 | Maintenance mode 2 | | Steps ins. | Always Steps inserted |
| P19.06 | Maintenance interval 3 | h | 9000 | 1 - 30000 |
| P19.07 | Maintenance mode 3 | | Steps ins. | Always Steps inserted |
| P19.08 | Number of maintenance insertions | kcnt | 120 | OFF/ 1-200 |

P19.01 – If set to ON, when switching from AUT to MAN mode, steps are disconnected in sequence.

P19.02...P19.07 – Defines three intervals of scheduled maintenance. For each of the three intervals, the duration in hours and the counting mode can be set.

Always = Count always active when the controller is powered.

Steps ins. = Hour count is incremented only when one or more steps are inserted/connected. When the time elapses, alarms, respectively A20, A21, A22, are generated (alarms must be enabled).

P19.08 – Defines the number of operations of the steps (considering the step with the highest count) beyond which alarm A23 is generated.

| M20 - LIMIT THRESHOLDS (LIMn, n=1...16) | | UoM | Default | Range |
|---|-----------------------|-----|---------|---------------------|
| P20.n.01 | Reference measurement | | OFF | OFF- (measurement) |
| P20.n.02 | Channel number x | | 1 | OFF / 1-99 |
| P20.n.03 | Function | | Max | Max - Min - Min+Max |
| P20.n.04 | Upper threshold | | 0 | -9999 to +9999 |
| P20.n.05 | Multiplier | | x1 | /100 to x100k |
| P20.n.06 | Delay | s | 0 | 0.0 – 600.0 |
| P20.n.07 | Lower threshold | | 0 | -9999 to +9999 |
| P20.n.08 | Multiplier | | x1 | /100 to x100k |
| P20.n.09 | Delay | s | 0 | 0.0 – 600.0 |
| P20.n.10 | Idle state | | OFF | OFF-ON |
| P20.n.11 | Memory | | OFF | OFF-ON |

Note: This menu is divided into 16 sections for the limit thresholds LIM1...16

P20.n.01 – Defines at which measurements supplied by DCRG8/DCRG8IND to apply the limit threshold.

P20.n.02 – The channel is defined when the reference measurement is an internal multichannel measurement (AINx for example).

P20.n.03 – Defines the operating mode of the limit threshold.

Max = LIMn enabled when the measurement exceeds P20.n.04 and P20.n.07 is the reset threshold.

Min = LIMn enabled when the measurement is less than P20.n.07 and P20.n.04 is the reset threshold.

Min+Max = LIMn enabled when the measurement is greater than P20.n.04 or less than P20.n.07.

P20.n.04 - P20.n.05 – Define the upper threshold, obtained by multiplying value P20.n.04 by P20.n.05.

P20.n.06 – Upper threshold tripping delay.

P20.n.07...P08.n.09 – As above but referred to the lower threshold.

P20.n.10 – Inverts the state of limit LIMn.

P20.n.11 – Defines whether the threshold remains latched and is cleared manually through commands menu (in ON) or if it resets automatically (in OFF).

| M21 - COUNTERS (CNTn, n=1...8) | | UoM | Default | Range |
|--------------------------------|----------------------------|-----|---------|----------------------------|
| P21.n.01 | Count source | | OFF | OFF-ON-INPx-OUTx-LIMx-REMX |
| P21.n.02 | Channel number x | | 1 | OFF / 1-99 |
| P21.n.03 | Multiplier | | 1 | 1-1000 |
| P21.n.04 | Divisor | | 1 | 1-1000 |
| P21.n.05 | Description of the counter | | CNTn | (Text - 16 characters) |
| P21.n.06 | Unit of measure | | Umn | (Text - 6 characters) |
| P21.n.07 | Reset source | | OFF | OFF-ON-INPx-OUTx-LIMx-REMX |
| P21.n.08 | Channel number x | | 1 | OFF / 1-99 |

Note: This menu is divided into 8 sections for counters CNT1...8.

P21.n.01 – Signal that increments the count (on rising edge). It may be energised by the DCRG8/DCRG8IND (ON), the exceeding of a threshold (LIMx), the activation of an external input (INPx), etc.

P21.n.02 – Channel number x with reference to the previous parameter.

P21.n.03 – Multiplier K. The counted pulses are multiplied by this value before being displayed.

P21.n.04 – Fractional K. The counted pulses are divided by this value before being displayed. If other than 1, the counter is displayed with 2 decimal points.

P21.n.05 – Counter description. 16-character free text.

P21.n.06 – Counter unit of measure. 6-character free text.

P21.n.07 – Signal that clears the count. As long as this signal is enabled, the count remains at zero.

P21.n.08 – Channel number x with reference to the previous parameter.

| M22 – ANALOG INPUTS (AINn, n=1...4) | | UoM | Default | Range |
|-------------------------------------|-------------------|-----|---------|---|
| P22.n.01 | Input type | | OFF | OFF - 0...20mA - 4...20mA - 0...10V - -5V...+5V - PT100 |
| P22.n.02 | Start scale value | | 0 | -9999 to +9999 |
| P22.n.03 | Multiplier | | x1 | /100 to x1k |
| P22.n.04 | End scale value | | 100 | -9999 to +9999 |
| P22.n.05 | Multiplier | | x1 | /100 to x1k |
| P22.n.06 | Description | | AINn | (Text - 16 characters) |
| P22.n.07 | Unit of measure | | UMn | (Text - 6 characters) |

Note: This menu is divided into 4 sections for the analog inputs AIN1...AIN4, available with the EXP1004 expansion modules.

P22.n.01 – Specifies the type of sensor connected to the analog input. The sensor should be connected to the appropriate terminal for the type selected. See expansion module manual.

P22.n.02 – P22.n.03 – Define the value to display for a sensor signal at minimum, i.e. start scale range defined by the type (0mA, 4mA, 0V, -5V).

Note: These parameters are not used for a PT100 sensor type.

P22.n.04 – P22.n.05 – Define the value to display for a sensor signal at maximum, i.e. start scale range defined by the type (20mA, 10V, +5V).

Note: These parameters are not used for a type PT100 sensor.

P22.n.06 – Description of measurements associated with analog input. 16-character free text.

P22.n.07 – Unit of measure. 6-character free text.

Example of application: The analogue input AIN3 must read a signal from a temperature sensor PT100, which must be indicated on the display with the description 'Temp. step 1'.

So, section 3 of this menu that is referred to AIN3 is programmed as follows:

P22.3.01 = PT100

P22.3.06 = 'Temp. step 1'

P22.3.07 = Degrees C.

| M23 – ANALOG OUTPUTS (AOUn, n=1...4) | | UoM | Default | Range |
|--------------------------------------|-----------------------|-----|---------|---|
| P23.n.01 | Output type | | OFF | OFF - 0...20mA - 4...20mA - 0...10V - -5V...+5V |
| P23.n.02 | Reference measurement | | OFF | OFF- (measurement) |
| P23.n.03 | Channel number x | | 1 | OFF / 1-99 |
| P23.n.04 | Start scale value | | 0 | -9999 to +9999 |
| P23.n.05 | Multiplier | | x1 | /100 to x100k |
| P23.n.06 | End scale value | | 0 | -9999 to +9999 |
| P23.n.07 | Multiplier | | x1 | /100 to x100k |

Note: This menu is divided into 4 sections for the analog outputs AOU1...AOU4 available when EXP1005 expansion module is used.

P23.n.01 – Specifies the type of output analog signal. The sensor should be connected to the appropriate terminal on the basis of the type selected. See expansion module manual.

P23.n.02 – Measurement on which the analog output value depends.

P23.n.03 – The channel is defined when the reference measurement is an internal multichannel measurement (AINx for instance).

P23.n.04 – P23.n.05 – Define the measurement value that corresponds to start scale (minimum) range (0mA, 4mA, 0V, -5V).

P23.n.06 – P23.n.07 – Define the measurement value that corresponds to end scale (maximum) range (20mA, 10V, +5V).

Application example: The analog output AOU2 must emit a 0...20mA signal proportional to the total active power, from 0 to 500kW.

So, section 2 of this menu that is referred to AOU2 is programmed as follows.

P23.2.01 = 0...20mA

P23.2.02 = kW tot

P23.2.03 = 1 (not used)

P23.2.04 = 0

P23.2.05 = x1

P23.2.06 = 500

P23.2.07 = x1k.

| M24 – PULSES (PULn, n=1...6) | | UoM | Default | Range |
|------------------------------|----------------|-----|---------|-----------------------------|
| P24.n.01 | Pulse source | | OFF | OFF / kWh- / kvarh- / kVAh+ |
| P24.n.02 | Counting unit | | 100 | 10/100/1k/10k |
| P24.n.03 | Pulse duration | s | 0.1 | 0.1-1.00 |

Note: This menu is divided into 6 sections, for the generation of energy consumption pulse variables PUL1...PUL6.

P24.n.01 – Defines which energy meter must generate the pulse, from the 6 possible meters managed by DCRG8/DCRG8IND.

kWh+ = imported active energy; **kWh-** = exported active energy; **kvarh+** = inductive reactive energy; **kvarh-** = capacitive reactive energy; **kVAh** = total apparent energy.

P24.n.02 – The quantity of energy which must accumulate for pulse emission (example: 10Wh or 100Wh or 1kWh).

P24.n.03 – Pulse duration.

Application example: For every 0.1 kWh output, a pulse of 500ms has to be generated on output OUT10.

First of all, an internal pulse variable needs to be generated, for instance PUL1. So, section 1 of this menu is programmed as follows:

P24.1.01 = kWh+ (imported active energy)

P24.1.02 = 100Wh (corresponding to 0.1 kWh)

P24.1.03 = 0.5

Now, output OUT10 (in menu M04) is set as follows linking it to pulse variable PUL1 above:

P04.10.01 = PULx

P04.10.02 = 1 (PUL1)

P04.10.03 = NOR.

| M25 – USER ALARMS (UAn, n=1...8) | | UoM | Default | Range |
|----------------------------------|-------------------------|-----|---------|-------------------------|
| P25.n.01 | Alarm source | | OFF | OFF-INPx-OUTx-LIMx-REMX |
| P25.n.02 | Channel number source x | | 1 | OFF / 1-99 |
| P25.n.03 | Text | | UAn | (text – 20 char) |

Note: This menu is divided into 8 sections for user alarms UA1...UA8.

P25.n.01 – Defines the digital input or internal variable that generates the user alarm when it is activated.

P25.n.02 – Channel number x relative to the previous parameter.

P25.n.03 – Free text that appears in the alarm window.

Application example: User alarm UA3 must be generated when input INP5 closes and must display the message 'Doors open'.

In this case, set the section of menu 3 (for alarm UA3) as follows:

P25.3.01 = INPx

P25.3.02 = 5

P25.3.03 = Doors open.

| M26 – ALARM PROPERTIES (ALAn, n=1...33) | | Default | Range |
|---|--------------------------|---------------------|--------------------------|
| P26.n.01 | Alarm enable | (see table page 21) | OFF – ON |
| P26.n.02 | Retentive | (see table page 21) | OFF - RET |
| P26.n.03 | Operating mode | (see table page 21) | AUT-MAN / AUT |
| P26.n.04 | Global alarm 1 | (see table page 21) | OFF – GLB1 |
| P26.n.05 | Global alarm 2 | (see table page 21) | OFF – GLB2 |
| P26.n.06 | Global alarm 3 | (see table page 21) | OFF – GLB3 |
| P26.n.07 | Step disconnection | (see table page 21) | OFF IMMEDIATE SLOW |
| P26.n.08 | Slave disconnection mode | (see table page 21) | GENERAL - LOCAL |
| P26.n.09 | Inhibition from input | (see table page 21) | OFF - INH |
| P26.n.10 | Modem call | (see table page 21) | OFF - MDM |
| P26.n.11 | Not shown on LCD | (see table page 21) | OFF - NOLCD |
| P26.n.12 | Alarm delay | (see table page 21) | OFF/ 1-120 |
| P26.n.13 | Delay UoM | (see table page 21) | MIN-SEC |

P26.n.01 – Enabled - General enabling of the alarm. If the alarm is not enabled, it is not considered as if it did not exist.

P26.n.02 – Retentive - Remains stored even if the cause of the alarm has been eliminated.

P26.n.03 – Operating mode – Operating mode in which the alarm is generated.

P26.n.04...P26.n.06 – Global alarm 1 -2 -3 – Activates the output assigned to this function.

P26.n.07 – Step disconnection mode – Defines whether and how the capacitor steps must be disconnected when the alarm is present. Choice among:

OFF = no disconnection; **SLOW** = gradual disconnection; **FAST** = Immediate disconnection.

P26.n.08 – Slave disconnection mode – For Master-Slave applications, if this alarm arises, it defines whether the disconnection is extended to all the steps of the system (GENERAL) or only to the output of the involved panel (LOCAL).

P26.n.09 – Inhibition - The alarm can be temporarily disabled by activating an input that can be programmed with the inhibit alarm function.

P26.n.10 – Modem call - A modem is connected as configured in setup.

P26.n.11 – No LCD - The alarm is normally managed, but not viewed on the display.

P26.n.12 – P26.n.13 – Delay time - Time delay in minutes or seconds before the alarm is generated.

ALARMS

- When an alarm is generated, the display will show an alarm icon, the code and the description of the alarm in the language selected.

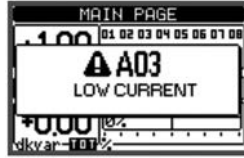

- If the navigation keys in the pages are pressed, the pop-up window showing the alarm indications will momentarily disappear and reappear again after a few seconds.
- The red LED near the alarm icon on the front panel is flashing when an alarm is active.
- If enabled, the local and remote alarm buzzers are activated.
- Alarms can be cleared by pressing .
- If the alarm cannot be cleared, the condition that generated the alarm must still be solved.
- If one or more alarms occur, the behaviour of the DCRG8/DCRG8IND will depend on the active alarm property setting.

ALARM DESCRIPTION

| CODE | ALARM | DESCRIPTION |
|------|--|---|
| A01 | Undercompensation | All the available steps are connected but the cosphi is still more inductive than the setpoint. |
| A02 | Overcompensation | All the steps are disconnected but the cosphi is still more capacitive than the setpoint. |
| A03 | Current too low | The current flowing in the current inputs is lower than minimum value of measurement range. This condition can occur normally if the plant has no load. |
| A04 | Current too high | The current flowing in the current inputs is higher than the maximum of measurement range. |
| A05 | Voltage too low | The measured voltage is lower than the threshold set with P17.14. |
| A06 | Voltage too high | The measured voltage is higher than the threshold set with P17.13. |
| A07 | Panel temperature too high | The panel temperature is higher than threshold set with P17.06. |
| A08 | Capacitor current overload | The calculated capacitor current overload is higher than threshold set with P17.08 and/or P17.09. |
| A09 | No-Voltage release | A no-voltage release has occurred on the line voltage inputs for more than 8ms. |
| A10 | Step xx failure | The residual power percentage of the step xx is lower than minimum threshold set with P17.12. |
| A11 | Harmonic protection module no. n Current too high | The RMS current measured by harmonic protection module n is higher than threshold set with P18.n.06. |
| A12 | Harmonic protection module no. n I-THD too high | The current THD measured by harmonic protection module n is higher than threshold set with P18.n.07. |
| A13 | Harmonic protection module no. n 5th Harm too high | The component percentage of 5th harmonic content measured by harmonic protection module n is higher than threshold set with P18.n.08. |
| A14 | Harmonic protection module no. n 7th Harm too high | The component percentage of 7th harmonic content measured by harmonic protection module n is higher than threshold set with P18.n.09. |
| A15 | Harmonic protection module no. n 11th Harm too high | The component percentage of 11th harmonic content measured by harmonic protection module n is higher than threshold set with P18.n.10. |
| A16 | Harmonic protection module no. n 13th Harm too high | The component percentage of 13th harmonic content measured by harmonic protection module n is higher than threshold set with P18.n.11. |
| A17 | Harmonic protection module no. n Temperature 1 too high | The measurement of temperature 1 input on harmonic protection module n is higher than threshold set with P18.n.12. |
| A18 | Harmonic protection module no. n Temperature 2 too high | The measurement of temperature 2 input on harmonic protection module n is higher than threshold set with P18.n.13. |
| A19 | Slave xx link error | The slave no. x does not communicate with the master. Problem with the RS485 wiring. |
| UAx | User alarm x (x=1..8) | User-defined alarm, as specified by parameters of menu M25. |
| A20 | Maintenance interval 1 elapsed | The maintenance 1 interval hours are elapsed. After maintenance service, reset counter with command C16. |
| A21 | Maintenance interval 2 elapsed | The maintenance 2 interval hours are elapsed. After maintenance service, reset counter with command C17. |
| A22 | Maintenance interval 3 elapsed | The maintenance 3 interval hours are elapsed. After maintenance service, reset counter with command C18. |
| A23 | Maintenance interval 4 elapsed | The maintenance 4 interval hours are elapsed. After maintenance service, reset counter with command C19. |
| A24 | THDV too high | The voltage THD measured is higher than threshold set with P17.15. |
| A25 | THDI too high | The current THD measured is higher than threshold set with P17.16. |

ALARM PROPERTIES

Various properties can be assigned to each alarm, including user alarms (User Alarms, UAx):

- Enabled** - General enabling of the alarm. If the alarm is not enabled, it is not considered.
- Retentive** - Memory remains latched even if the cause of the alarm has been eliminated.
- Operating mode** - Operating modes in which the alarm is enabled.
- Global alarm 1 -2 -3** - Activates the output assigned to this function.
- Step disconnection mode** - Defines whether and how the capacitor steps must be disconnected when the alarm is present. **OFF** = no disconnection; **SLOW** = gradual disconnection; **FAST** = Immediate disconnection.
- Slave disconnection mode** - Defines, for Master-Slave applications when this alarm arises, if the disconnection is extended to all the steps of the system (GENERAL) or only to the output of the interested panel (LOCAL).
- Inhibition** - The alarm can be temporarily disabled by activating an input that can be programmed with the Inhibit function.
- Modem call** - The alarm will be signalled remotely by sending a modem call under the conditions and modality defined in modem parameters.
- No LCD** - The alarm is managed normally, but not shown on the display.
- Delay time** - Time delay in minutes or seconds before the alarm is generated.

ALARM PROPERTY TABLE

| CODE | DEFAULT ALARM PROPERTIES | | | | | | | | | | | | | |
|------|--------------------------|-----------|------------------|----------------|----------------|----------------|-------------------------|--------------------------|---------|-------|--------|------------|-----|-----|
| | Enabled | Retentive | Only in AUI mode | Global alarm 1 | Global alarm 2 | Global alarm 3 | Step disconnection mode | Slave disconnection mode | Inhibit | Modem | No LCD | Delay time | min | sec |
| A01 | ● | | ● | ● | | | OFF | GEN | | ● | | 15 | ● | |
| A02 | ● | | ● | | | | OFF | GEN | | ● | | 120 | | ● |
| A03 | ● | | ● | | | | SLO | GEN | | ● | | 5 | | ● |
| A04 | ● | | ● | ● | | | OFF | GEN | | ● | | 120 | | ● |
| A05 | ● | | ● | ● | | | OFF | GEN | | ● | | 5 | | ● |
| A06 | ● | | ● | ● | | | OFF | GEN | | ● | | 15 | ● | |
| A07 | ● | | ● | ● | | | SLO | LOC | | ● | | 30 | | ● |
| A08 | ● | | ● | ● | | | SLO | LOC | | ● | | 30 | | ● |
| A09 | ● | | | | | | IMM | GEN | | ● | | 0 | | ● |
| A10 | ● | ● | ● | ● | | | OFF | GEN | | ● | | 0 | | ● |
| A11 | ● | | ● | ● | | | SLO | LOC | | ● | | 3 | ● | |
| A12 | ● | | ● | ● | | | SLO | LOC | | ● | | 3 | ● | |
| A13 | ● | | ● | ● | | | SLO | LOC | | ● | | 3 | ● | |
| A14 | ● | | ● | ● | | | SLO | LOC | | ● | | 3 | ● | |
| A15 | ● | | ● | ● | | | SLO | LOC | | ● | | 3 | ● | |
| A16 | ● | | ● | ● | | | SLO | LOC | | ● | | 3 | ● | |
| A17 | ● | | ● | ● | | | SLO | LOC | | ● | | 10 | | ● |
| A18 | ● | | ● | ● | | | SLO | LOC | | ● | | 10 | | ● |
| A19 | ● | | | ● | | | SLO | GEN | | ● | | 0 | | ● |
| UA1 | | | | | | | OFF | GEN | | | | 0 | | ● |
| UA2 | | | | | | | OFF | GEN | | | | 0 | | ● |
| UA3 | | | | | | | OFF | GEN | | | | 0 | | ● |
| UA4 | | | | | | | OFF | GEN | | | | 0 | | ● |
| UA5 | | | | | | | OFF | GEN | | | | 0 | | ● |
| UA6 | | | | | | | OFF | GEN | | | | 0 | | ● |
| UA7 | | | | | | | OFF | GEN | | | | 0 | | ● |
| UA8 | | | | | | | OFF | GEN | | | | 0 | | ● |
| A20 | | | | ● | | | OFF | GEN | | ● | | 0 | ● | |
| A21 | | | | ● | | | OFF | GEN | | ● | | 0 | ● | |
| A22 | | | | ● | | | OFF | GEN | | ● | | 0 | ● | |
| A23 | | | | ● | | | OFF | GEN | | ● | | 0 | ● | |
| A24 | ● | | ● | ● | | | OFF | GEN | | ● | | 120 | | ● |
| A25 | ● | | ● | ● | | | OFF | GEN | | ● | | 120 | | ● |

COMMANDS MENU

- The commands menu allows executing some occasional operations, such as measurement reset, counter clearing, alarm reset, etc.
- If the advanced access password was entered, the control menu can also be used to perform automatic operations useful for configuring the controller.
- The following table lists the functions available in the commands menu, divided by the access level required.

| CODE | COMMAND | ACCESS LEVEL | DESCRIPTION |
|------|---------------------------------------|--------------|---|
| C01 | Reset partial energy meter | Usr | Clears partial energy meter |
| C02 | Reset CNTx counter | Usr | Clears programmable general counters CNTx |
| C03 | Reset LIMx status | Usr | Resets status of latched LIMx variables |
| C04 | Reset max temperature | Adv | Clears maximum temperature peak value |
| C05 | Reset max overload | Adv | Clears maximum overload peak value |
| C06 | Reset step hour count | Adv | Clears hour counters of step operation |
| C07 | Reset step switching counters | Adv | Clears counters of step switchings |
| C08 | Step power restore | Adv | Reloads originally programmed power values in step trimming |
| C09 | Reset total energy meter | Adv | Clears total energy meters |
| C10 | TEST mode activation | Adv | Enables the TEST mode operation of outputs |
| C11 | Event log reset | Adv | Clears the event log memory |
| C12 | Setup to default | Adv | Resets setup programming to factory default |
| C13 | Backup setup | Adv | Makes a backup copy of user setup of parameters |
| C14 | Restore setup | Adv | Reloads parameters with the user setup backup |
| C15 | Reset weekly TPF | Usr | Clears the weekly Total Power Factor stored history |
| C16 | Reset maintenance interval 1 elapsed* | Adv | Resets the hour counting for service interval 1 |
| C17 | Reset maintenance interval 2 elapsed | Adv | Resets the hour counting for service interval 2 |
| C18 | Reset maintenance interval 3 elapsed | Adv | Resets the hour counting for service interval 3 |
| C19 | Reset maintenance interval 4 elapsed | Adv | Resets the hour counting for service interval 4 |

- Once the required command has been selected, press ✓ to execute it. The device will prompt a confirmation. By pressing ✓ again, the command is executed.
- To cancel the command execution press ◀.
- To quit the commands menu press ◀.

* The hour counter can be reset for maintenance interval 1 also by accessing the dedicated page and holding down the ◀ button for three seconds.

MEASUREMENT TABLE FOR LIMIT THRESHOLDS AND ANALOG OUTPUTS

- The following table lists all measurements that can be associated with the limit thresholds (menu M20) and analog outputs (menu M23).
- The codes selected in the parameters P20.n.01 and P23.n.02 correspond to the measurements below.
- To facilitate the comparison with three-phase measurements, some 'virtual' values are provided that are the highest measurements across the three phases. These measurements are identified by the presence of the word MAX in the measurement code.

Example: If you want to apply a maximum limit of 10% on the 5th harmonic current content of the system when you have a three-phase current, set LIM1 to H. I MAX, with channel no. set to 5. The device will consider the highest of the harmonic content of the 5th order among the three currents I L1, I L2 and I L3.

Settings:

P20.1.01 = H. I MAX (highest current harmonic among 3 phases)
 P20.1.02 = 5 (5th harmonic)
 P20.1.03 = max (compare with max threshold)
 P20.1.04 = 10 (threshold = 10%)

....

| NO. | MEASUREMENT CODE | DESCRIPTION |
|-----|------------------|--|
| 00 | OFF | Measurement disabled |
| 01 | V L1-N | Phase voltage L1-N |
| 02 | V L2-N | Phase voltage L2-N |
| 03 | V L3-N | Phase voltage L3-N |
| 04 | I L1 | Phase current L1 |
| 05 | I L2 | Phase current L2 |
| 06 | I L3 | Phase current L3 |
| 07 | V L1-L2 | Phase-to-phase voltage L1-L2 |
| 08 | V L2-L3 | Phase-to-phase voltage L2-L3 |
| 09 | V L3-L1 | Phase-to-phase voltage L3-L1 |
| 10 | W L1 | Active power L1 |
| 11 | W L2 | Active power L2 |
| 12 | W L3 | Active power L3 |
| 13 | var L1 | Reactive power L1 |
| 14 | var L2 | Reactive power L2 |
| 15 | var L3 | Reactive power L3 |
| 16 | VA L1 | Apparent power L1 |
| 17 | VA L2 | Apparent power L2 |
| 18 | VA L3 | Apparent power L3 |
| 19 | Hz | Frequency |
| 20 | Cosphi L1 | Cosphi L1 |
| 21 | Sinphi L1 | Sinphi L1 |
| 22 | Cosphi L2 | Cosphi L2 |
| 23 | Sinphi L2 | Sinphi L2 |
| 24 | Cosphi L3 | Cosphi L3 |
| 25 | Sinphi L3 | Sinphi L3 |
| 26 | W TOT | Total active power |
| 27 | var TOT | Total reactive power |
| 28 | VA TOT | Total apparent power |
| 29 | Cosphi TOT | Cosphi (balanced three-phase system) |
| 30 | Sinphi TOT | Sinphi (balanced three-phase system) |
| 31 | THD VLN MAX | THD phase voltage (maximum among phases) |
| 32 | THD I MAX | THD phase current (maximum among phases) |
| 33 | THD VLL MAX | THD phase-phase voltage (maximum among phases) |
| 34 | H. VLN MAX | Phase voltage harmonic content of order n (maximum among phases) |
| 35 | H. I MAX | Phase current harmonic content of order n (maximum among phases) |
| 36 | H. VLL MAX | Phase-phase voltage harmonic content of order n (maximum among phases) |
| 37 | Cosphi MAX | Cosphi (maximum among phases) |
| 38 | Sinphi MAX | Sinphi (maximum among phases) |
| 39 | VLN MAX | Phase voltage (maximum among phases) |
| 40 | I MAX | Current (maximum among phases) |
| 41 | VLL MAX | Phase-phase voltage (maximum among phases) |
| 42 | VLN MIN | Phase voltage (minimum among phases) |
| 43 | VLL MIN | Phase-phase voltage (minimum among phases) |
| 44 | Cosphi MIN | Cosphi (minimum among phases) |
| 45 | AIN | Measurement from analog inputs |
| 46 | CNT | Programmable counter |

EVENTS LIST

| CODE | SYSTEM |
|-------|-------------------------|
| E0000 | ACTIVATION |
| E0001 | SWITCHING OFF |
| E0002 | SYSTEM RESET |
| | ALARMS |
| E0200 | ALARM START |
| E0201 | ALARM END |
| E0202 | ALARM RESET |
| E0203 | ALARMS ACTIVATED |
| | LIMITS |
| E0300 | ON THRESHOLD |
| E0301 | OFF THRESHOLD |
| | LIMITS |
| E0500 | IR START |
| E0501 | IR END |
| | MODEM |
| E0600 | OUTGOING CALL 1 |
| E0601 | OUTGOING CALL 2 |
| E0602 | INCOMING CALL |
| E0603 | CALL 1 OK |
| E0604 | CALL 2 OK |
| E0605 | CALL ENDED |
| E0606 | CALL 1 FAILED |
| E0607 | CALL 12 FAILED |
| E0608 | INPUT CALL OK |
| E0609 | INPUT CALL FAILED |
| E0610 | SMS DELIVERY 1 |
| E0611 | SMS DELIVERY 2 |
| E0612 | SMS DELIVERY 3 |
| E0613 | SMS DELIVERY 1 OK |
| E0614 | SMS 2 SENT OK |
| E0615 | SMS 3 SENT OK |
| E0616 | SMS DELIVERY 1 FAILED |
| E0617 | SMS DELIVERY 2 FAILED |
| E0618 | SMS DELIVERY 3 FAILED |
| E0619 | SMS RECEIVED |
| E0620 | SMS RECEIVED OK |
| E0621 | SMS RECEPTION FAILED |
| E0622 | E-MAIL DELIVERY |
| E0623 | E-MAIL DELIVERY OK |
| E0624 | E-MAIL DELIVERY FAILED |
| E0625 | FTP EVENT DELIVERY |
| E0626 | FTP STATUS DELIVERY |
| E0627 | FTP EVENT DELIVERY OK |
| E0628 | FTP STATUS OK |
| E0629 | FTP EV. DELIVERY FAILED |
| E0630 | FTP STATUS FAILED |
| E0631 | GMS RESTART |
| E0632 | GSM SERV. RESET |
| E0633 | PERIODIC CALL |

| CODE | ACCESS |
|-------|-----------------------|
| E0700 | SETUP MENU ACCESS |
| E0703 | CLOCK SET.ACCESS |
| | COMMANDS |
| E0800 | C01 RES. PART. ENERG. |
| E0801 | C02 RES. CNT |
| E0802 | C03 RESET LIMITS |
| E0803 | C04 RES. MAX. TEMP. |
| E0804 | C05 RESET MAX. OVRL. |
| E0805 | C06 RES. STEP HOURS |
| E0806 | C07 RES. STEP OPER. |
| E0807 | C08 REST. STEP POWR. |
| E0808 | C09 RES. TOT. ENERGY |
| E0809 | C10 REST. TEST MODE |
| E0810 | C11 RES. EVENT MEM. |
| E0811 | C12 SETUP TO DEFAULT |
| E0812 | C13 BACKUP SETUP |
| E0813 | C14 RESTORE SETUP |
| E0814 | C15 RES. WEEKL. TPF K |
| E0815 | C16 RES. MAINTEN. 1 |
| E0816 | C17 RES. MAINTEN. 2 |
| E0817 | C18 RES. MAINTEN. 3 |
| E0818 | C19 RESET HI |
| | PASSWORD |
| E0900 | USER LEVEL |
| E0901 | ADVANCED LEVEL |
| E0902 | REMOTE CONTROL |
| E0903 | UNLOCKING |
| E0905 | CUSTOM SETUP |
| | EXPANSIONS |
| E1000 | NEW CONFIGURATION |
| | MODE CHANGE |
| E1101 | MAN MODE |
| E1102 | AUT MODE |
| | STEP STATUS |
| E2000 | CONNECTED |
| E2001 | DISCONNECTED |
| | DONGLE MENU |
| E2400 | ENABLED |
| E2401 | DISABLED |
| E2402 | SETUP DEVICE TO CX02 |
| E2403 | SETUP CX02 TO DEVICE |
| E2404 | CLONE DEVICE TO CX02 |
| E2405 | CLONE CX02 TO DEVICE |

WIRING DIAGRAMS
Standard three-phase installation

1340 GB 02 21

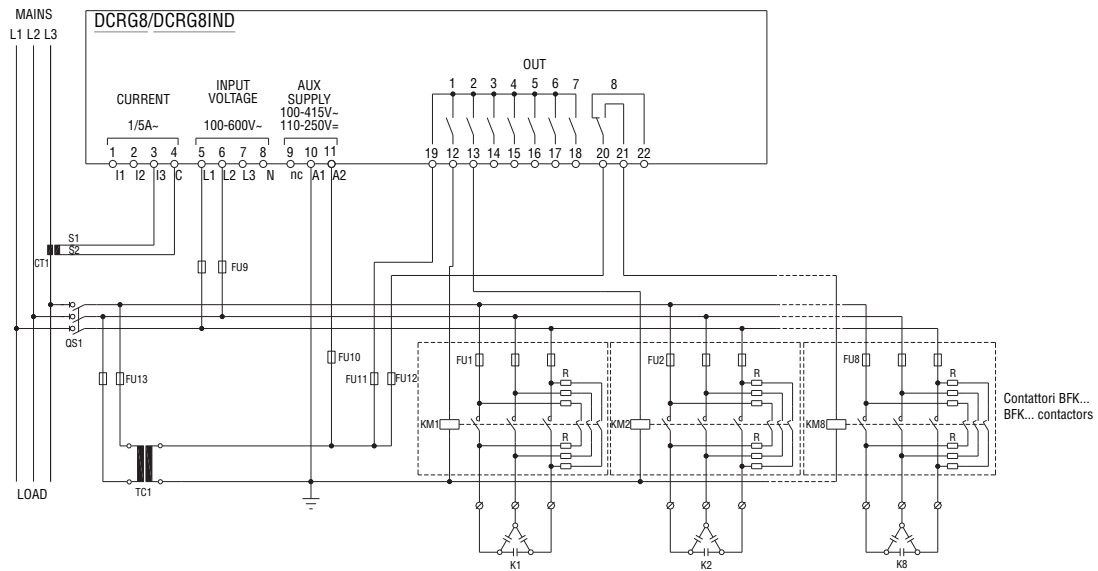

| THREE-PHASE CONNECTION (default) - Default wiring configuration for standard applications | |
|---|--|
| Voltage measurement | 1 ph-to-ph voltage reading L1-L2 |
| Current measurement | L3 phase |
| Phase angle offset | Between V (L1-L2) and I (L3) $\rightarrow 90^\circ$ |
| Capacitor overload measurement | 1 reading calculated on L1-L2 |
| Parameter setting | P02.03 = Three-phase P02.22 = LV P02.04 = L3 P02.06 = L1-L2 |

NOTE: Recommended fuses for aux supply and voltage measurement inputs: F1A (fast).

Single-phase installation

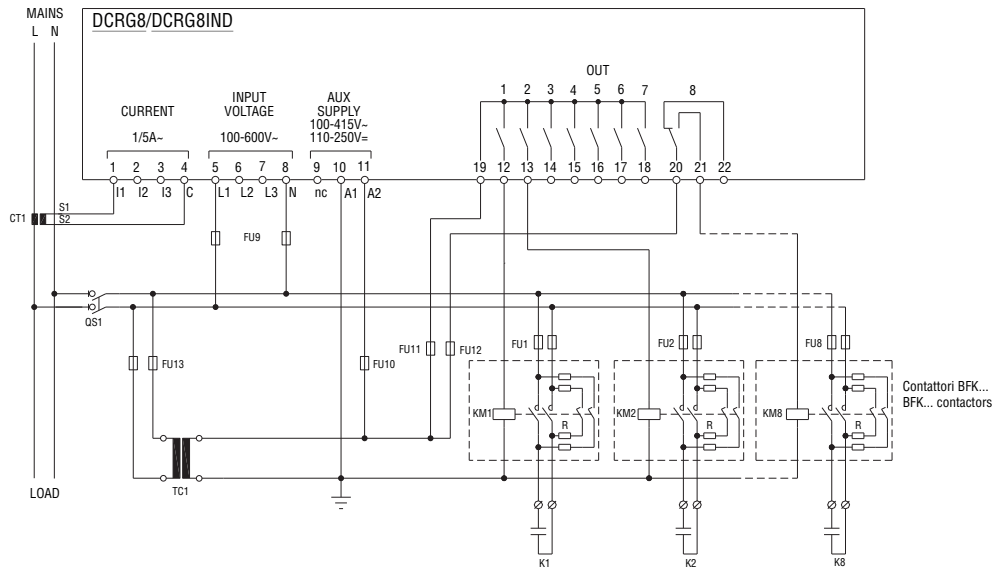

| SINGLE-PHASE CONNECTION - Wiring configuration for single-phase applications | |
|--|--|
| Voltage measurement | 1 phase voltage reading L1-N |
| Current measurement | L1 phase |
| Phase angle offset | Between V (L1-N) and I (L1) $\rightarrow 0^\circ$ |
| Capacitor overload measurement | 1 reading calculated on L1-N |
| Parameter setting | P02.03 = Single-phase P02.22 = LV P02.04 = L1 P02.06 = L1-N |

NOTE: Recommended fuses for aux supply and voltage measurement inputs: F1A (fast).

Full three-phase installation, without neutral

1340 GB 02 21

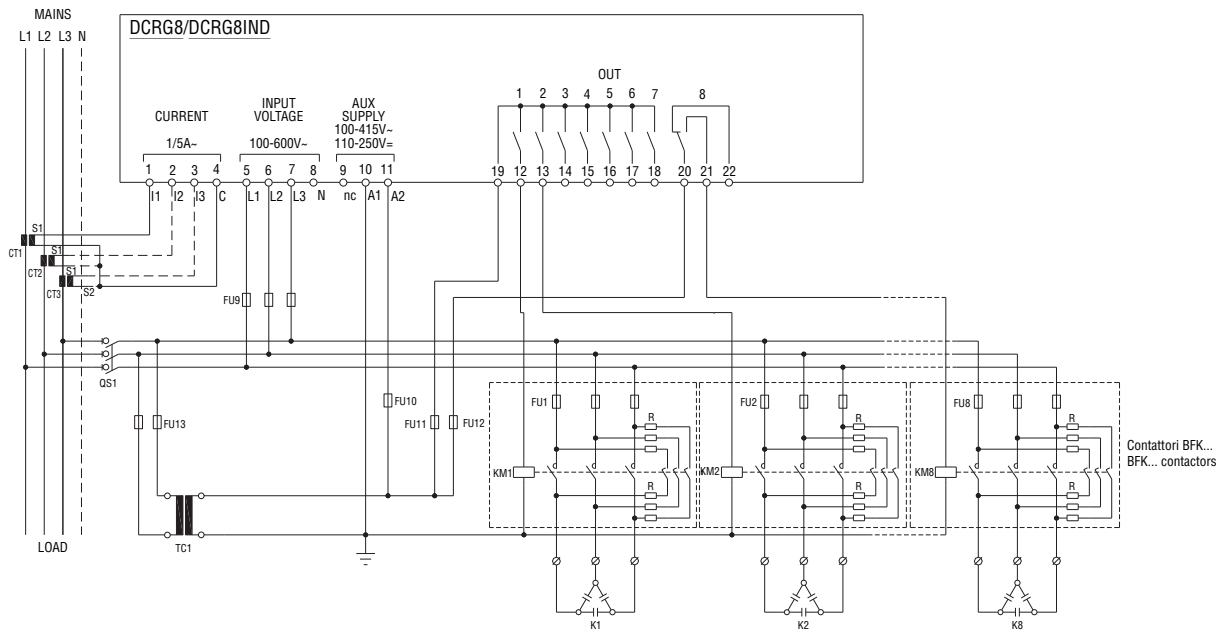

FULL THREE-PHASE CONNECTION, WITHOUT NEUTRAL - Wiring configuration used for standard applications with full three-phase voltage control

| | | |
|--------------------------------|--|-------------|
| Voltage measurement | 3 ph-to-ph voltage readings L1-L2, L2-L3, L3-L1 | |
| Current measurement | L1-L2-L3 phases | |
| Phase angle offset | 90° | |
| Capacitor overload measurement | 3 readings calculated on L1-L2, L2-L3, L3-L1 | |
| Parameter setting | P02.03 = Three-phase P02.04 = L1-L2-L3 P02.06 = L1-L2-L3 | P02.22 = LV |

NOTE: Recommended fuses for aux supply and voltage measurement inputs: F1A (fast).

Full three-phase installation, with neutral

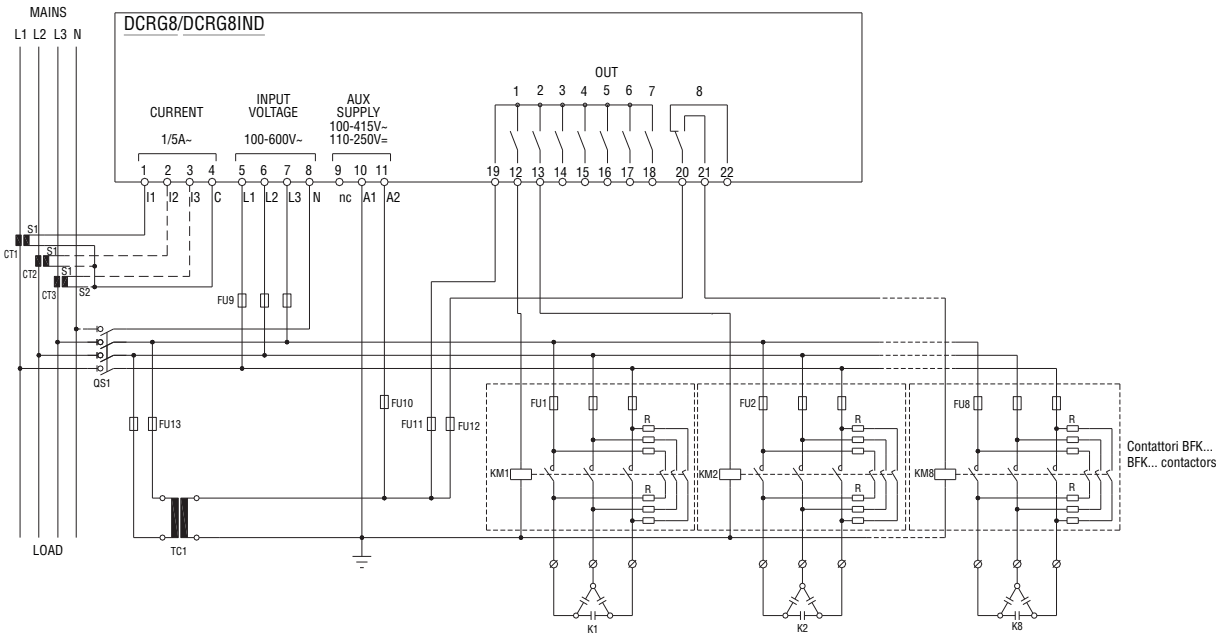

FULL THREE-PHASE CONNECTION, WITH NEUTRAL - Wiring configuration used for standard applications with full three-phase voltage control

| | | |
|--------------------------------|---|-------------|
| Voltage measurement | 3 ph-to-n and 3 ph-to-ph voltage readings L1-N, L2-N, L3-N, L1-L2, L2-L3, L3-L1 | |
| Current measurement | L1-L2-L3 phases | |
| Phase angle offset | 0° | |
| Capacitor overload measurement | 3 readings calculated on L1-L2, L2-L3, L3-L1 | |
| Parameter setting | P02.03 = Three-phase P02.04 = L1-L2-L3 P02.06 = L1-L2-L3-N | P02.22 = LV |

NOTE: Recommended fuses for aux supply and voltage measurement inputs: F1A (fast).

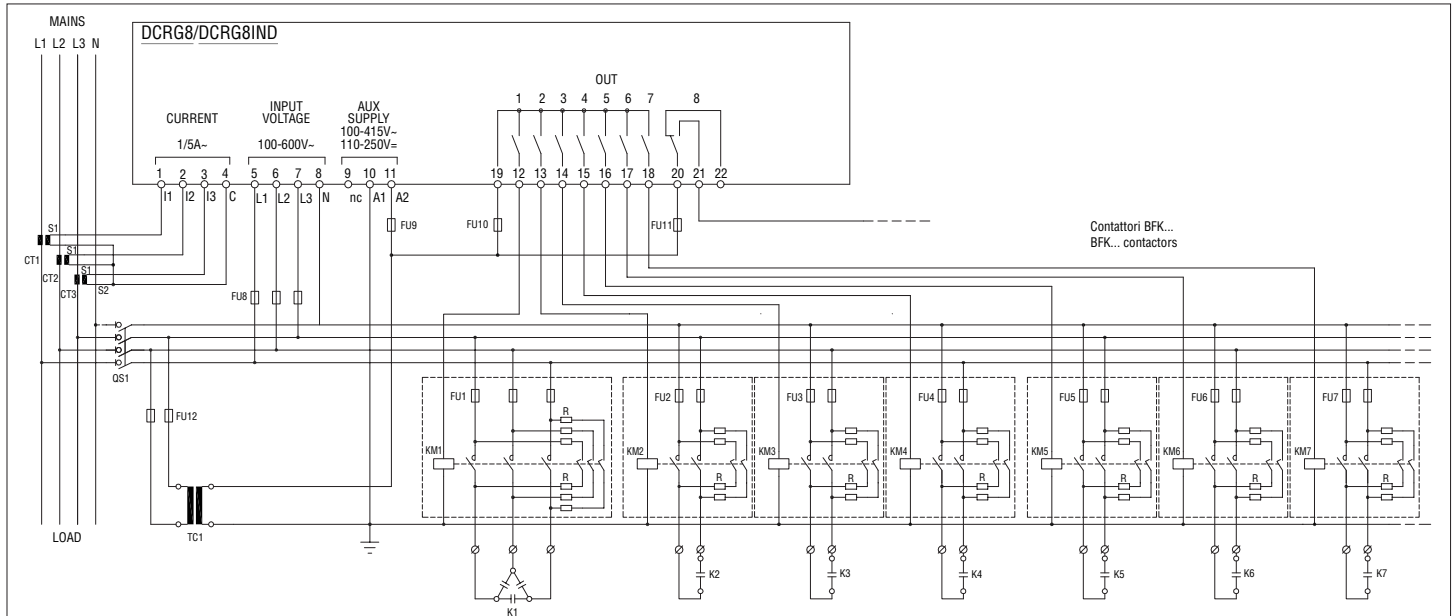

| COMPLETE THREE-PHASE WIRING, WITH NEUTRAL - Configuration for highly unbalanced applications with power factor correction by single phase and complete three-phase voltage control | | |
|--|---|-------------|
| Voltage measurement | 3 measurements for phase voltage and phase-to-phase L1-N, L2-N, L3-N, L1-L2, L2-L3, L3-L1 | |
| Current measurement | Phases L1-L2-L3 | |
| Phase angle offset | 90° | |
| Capacitor overload measurement | 3 measurements calculated on L1-L2, L2-L3, L3-L1 | |
| Parameter settings | P02.03 = Single-phase P02.04 = L1-L2-L3 P02.06 = L1-L2-L3-N | P02.22 = LV |

NOTE: Fuses recommended for auxiliary supply and voltage measurement input: F1A (fast).

Example of minimal parameter programming for 400V system comprising one 60kvar three-phase step and six single-phase steps of 10kvar each:

- | | |
|---|----------------|
| P02.03 = Single-phase | P03.3.01 = 1 |
| P02.04 = L1-L2-L3 | P03.3.03 = L2 |
| P02.06 = L1-L2-L3-N | P03.4.01 = 1 |
| P02.07 = 10 (kvar) | P03.4.03 = L1 |
| P02.08 = 230 (volts) | P03.5.01 = 1 |
| P03.1.01 = 2 (60kvar three-phase step = 20kvar per phase) | P03.5.03 = L3 |
| P03.1.03 = L1-L2-L3 | P03.6.01 = 1 |
| P03.2.01 = 1 | P03.6.03 = L2 |
| P03.2.03 = L3 | P03.7.01 = 1 |
| | P03.7.03 = L1. |

Standard three-phase wiring with inductors

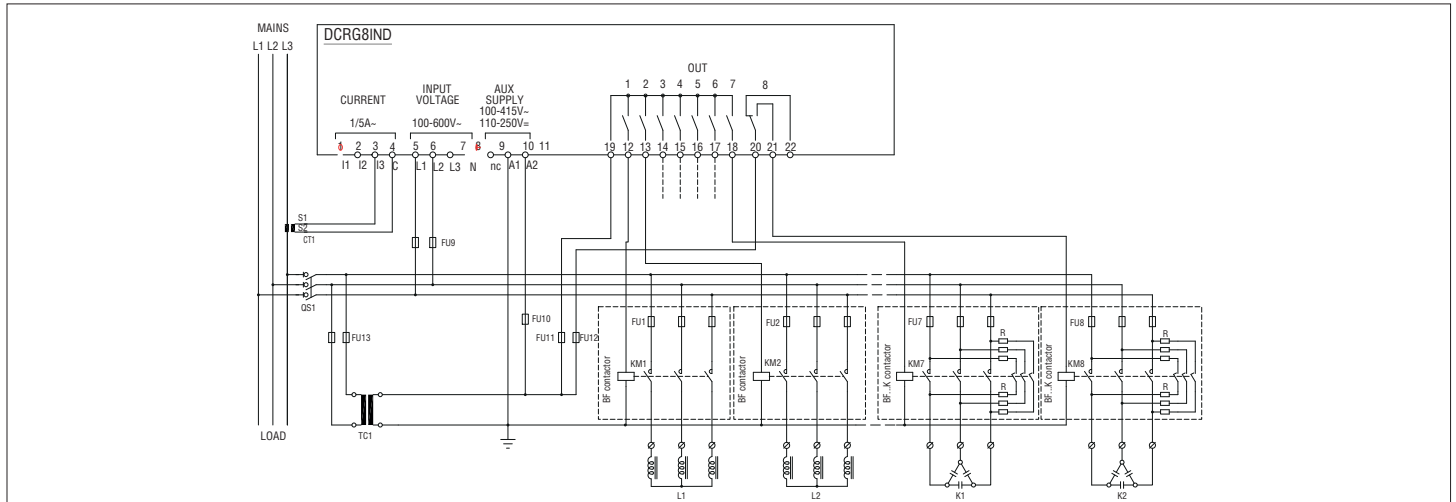

| STANDARD THREE-PHASE WIRING WITH INDUCTORS - DEFAULT CONFIGURATION FOR STANDARD APPLICATIONS | | |
|--|---|--|
| Voltage measurement | 1 phase-to-phase voltage measurement L1-L2 | |
| Current measurement | Phase L3 | |
| Phase angle offset | Between V (L1-L2) and I (L3) → 90° | |
| Capacitor overload measurement | 1 measurement calculated on L1-L2 | |
| Parameter settings | P02.03 = Three-phase P02.04 = L3 P02.06 = L1-L2 | P02.22 = LV P.03.1.04 = IND P.03.2.04 = IND — P.03.7.04 = CAP P.03.8.04 = CAP |

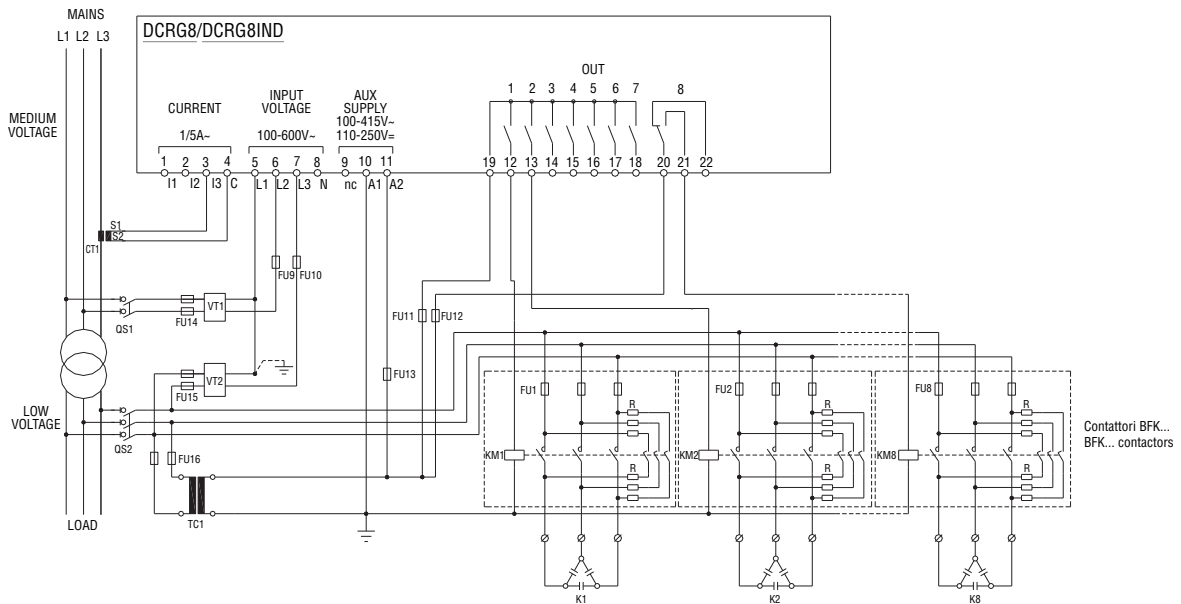

| CONFIGURATION WITH MV MEASUREMENT AND CORRECTION ON LV SIDE | | | | | | | |
|---|--|----------------------|----------------|-------------|-------------|----------------|--|
| Voltage measurement | 1 ph-to-ph voltage reading L1-L2 on MV side | | | | | | |
| Current measurement | L3 phase on MV side | | | | | | |
| Phase angle offset | 90° | | | | | | |
| Capacitor overload measurement | 1 reading calculated on L1-L3, on LV side | | | | | | |
| Parameter setting | <table border="0"> <tr> <td>P02.03 = Three-phase</td> <td>P02.22 = LV/MV</td> </tr> <tr> <td>P02.04 = L3</td> <td>P02.23 = ON</td> </tr> <tr> <td>P02.06 = L1-L2</td> <td></td> </tr> </table> | P02.03 = Three-phase | P02.22 = LV/MV | P02.04 = L3 | P02.23 = ON | P02.06 = L1-L2 | |
| P02.03 = Three-phase | P02.22 = LV/MV | | | | | | |
| P02.04 = L3 | P02.23 = ON | | | | | | |
| P02.06 = L1-L2 | | | | | | | |

NOTE: Recommended fuses for aux supply and voltage measurement inputs: F1A (fast).

Complete three-phase wiring, in MV

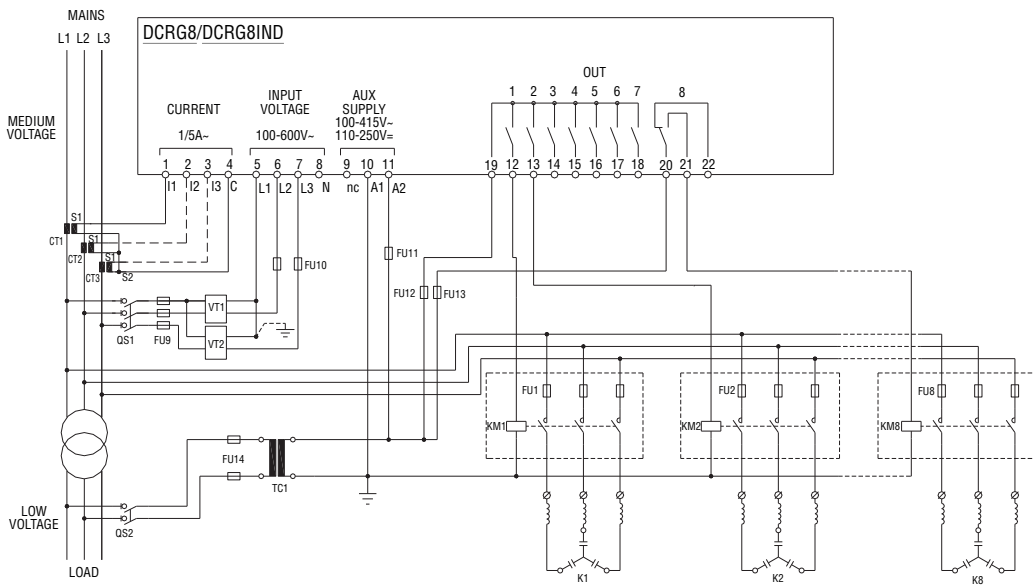

| CONFIGURATION WITH MV MEASUREMENT AND CORRECTION | | | | | | | |
|--|--|----------------------|-------------|-------------------|-------------|-------------------|--|
| Voltage measurement | 3 ph-to-ph voltage readings L1-L2, L2-L3, L3-L1 on MV side | | | | | | |
| Current measurements | L1-L2-L3 phases on MV side | | | | | | |
| Phase angle offset | 90° | | | | | | |
| Capacitor overload measurement | 3 readings calculated on L1-L2, L2-L3, L3-L1 | | | | | | |
| Parameter setting | <table border="0"> <tr> <td>P02.03 = Three-phase</td> <td>P02.22 = MV</td> </tr> <tr> <td>P02.04 = L1-L2-L3</td> <td>P02.23 = ON</td> </tr> <tr> <td>P02.06 = L1-L2-L3</td> <td></td> </tr> </table> | P02.03 = Three-phase | P02.22 = MV | P02.04 = L1-L2-L3 | P02.23 = ON | P02.06 = L1-L2-L3 | |
| P02.03 = Three-phase | P02.22 = MV | | | | | | |
| P02.04 = L1-L2-L3 | P02.23 = ON | | | | | | |
| P02.06 = L1-L2-L3 | | | | | | | |

NOTE: Recommended fuses for aux supply and voltage measurement inputs: F1A (fast).

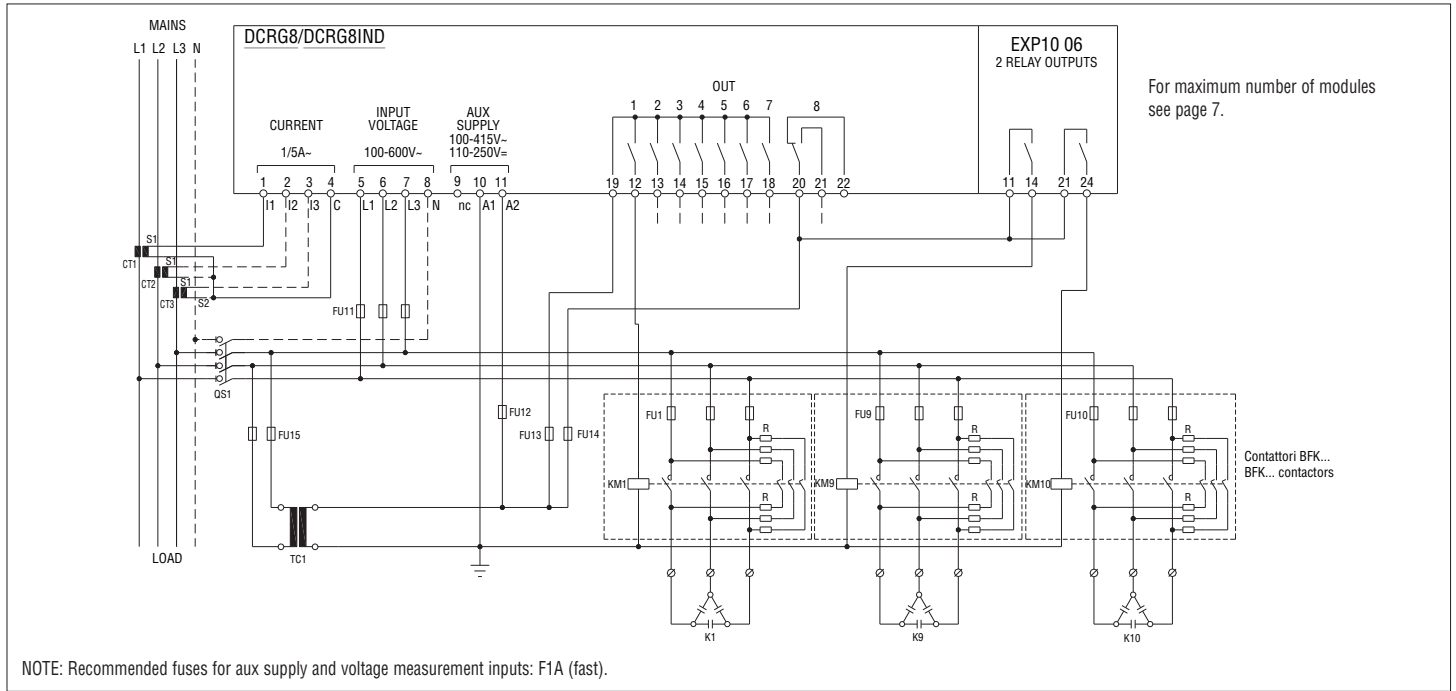

Insertion of static modules (FAST)

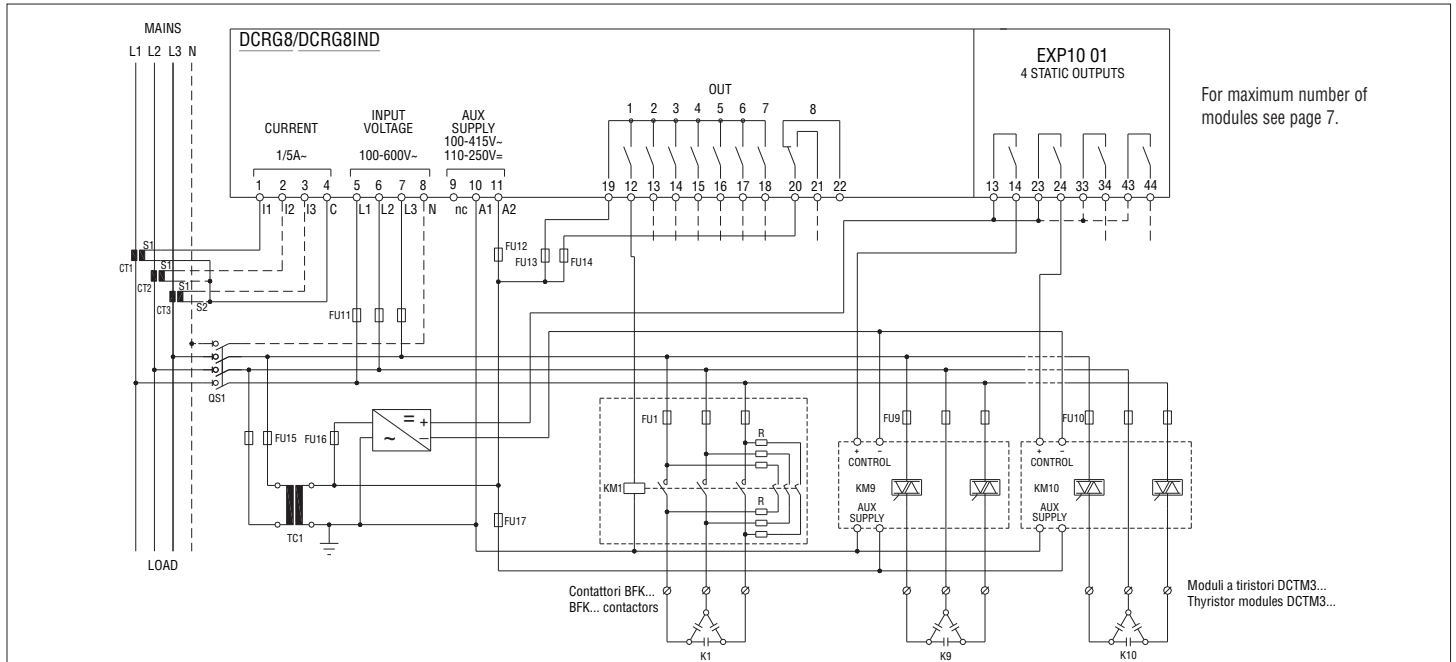

| STATIC CORRECTION | |
|--------------------------------|--|
| Voltage measurement | 3 ph-to-ph voltage readings L1-L2, L2-L3, L3-L1 |
| Current measurement | L1-L2-L3 phases |
| Phase angle offset | 90° |
| Capacitor overload measurement | 3 readings calculated on L1-L2, L2-L3, L3-L1 |
| Parameter setting | P02.03 = Three-phase P02.04 = L1-L2-L3 P02.06 = L1-L2-L3 |
| | P02.22 = LV P02.28 = Fast |

NOTE: Recommended fuses for aux supply and voltage measurement inputs: F1A (fast).

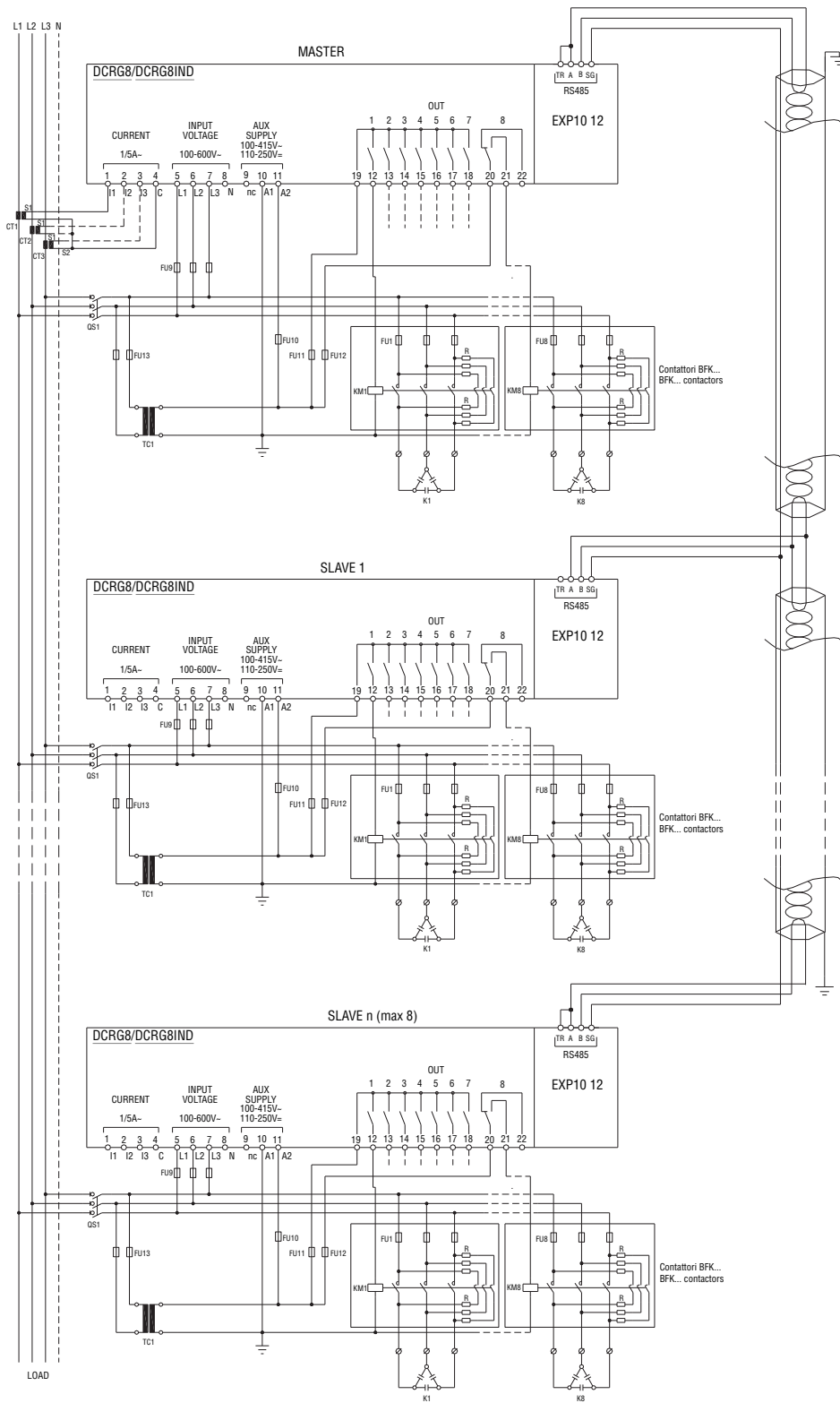

MASTER-SLAVE CONNECTION TYPE - Example with one master and 3 slaves

| MASTER | SLAVE 01 | SLAVE 02 | SLAVE 03 |
|------------------|------------------|------------------|------------------|
| P05.01 = COM1 | P05.01 = COM1 | P05.01 = COM1 | P05.01 = COM1 |
| P05.02 = Master | P05.02 = Slave01 | P05.02 = Slave02 | P05.02 = Slave03 |
| P05.03 = ON | | | |
| P05.04 = ON | | | |
| P05.05 = ON | | | |
| P04.1.01 = Stepx | | | |
| | | | |
| P06.1.01 = Stepx | | | |
| | | | |
| P07.1.01 = Stepx | | | |
| | | | |
| P08.1.02 = Stepx | | | |

NOTE: Recommended fuses for aux supply and voltage measurement inputs: F1A (fast).

TERMINAL ARRANGEMENT

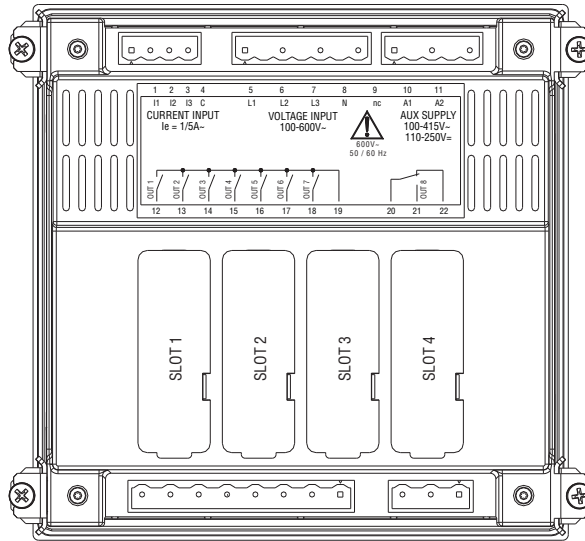

INSTALLATION

- DCRG8/DCRG8IND is designed for flush-mount installation. With proper mounting, it guarantees IP65 front protection degree.
- Insert the controller into the panel cutout, making sure the gasket is properly positioned between the panel surface and the controller front frame.
- Make sure the tab of the customising label does not get folded under the gasket and impair the seal gripping. It should be positioned inside the panel.
- From inside the panel, for each of the four fixing clips (standard supplied with the controller in plastic bag), position the clip in the appropriate square hole on the controller housing side, then move it backwards in order to insert its hook in place.

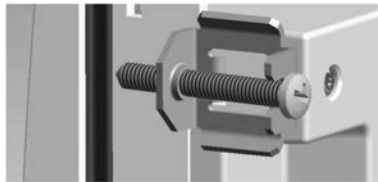

- Repeat the same operation for all four clips.
- Tighten the fixing screw with a maximum torque of 0.5Nm.
- In case the device needs to be removed, loosen the four clip screws and repeat the steps in reverse order.
- For the electrical connections, see the wiring diagrams in the dedicated chapter and the requirements given in the technical characteristics table.

MECHANICAL DIMENSIONS AND FRONT PANEL CUTOUT [mm]

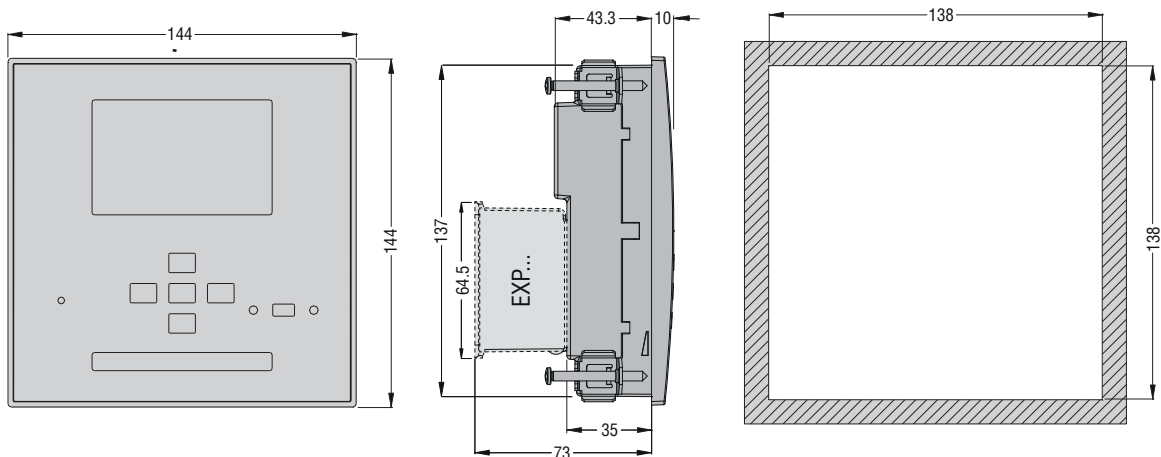

TECHNICAL CHARACTERISTICS

| Supply | |
|--------------------------------------|--|
| Rated voltage Us ^① | 100 - 415V~ 110 - 250V== |
| Operating voltage range | 90 - 456V~ 93.5 - 300V== |
| Frequency | 45 - 66Hz |
| Power consumption/dissipation | 10.5W / 27VA (measured with 4 EXP modules) |
| Power consumption/dissipation per UL | 5.5W / 15VA (measured with no EXP modules) |
| Immunity time for microbreakings | 110V~ ≥35ms; 220V - 415V~ ≥80ms |
| Voltage input | |
| Maximum rated voltage Ue | 600V~ L-L (346V~ L-N) |
| Measuring range | 50 - 720V L-L (415V~ L-N) |
| Frequency range | 45 - 66Hz / 360 - 440Hz |
| Measuring method | True RMS |
| Measuring input impedance | > 0,55MΩ L-N; > 1,10MΩ L-L |
| Wiring mode | Single-phase, two-phase, three-phase with or without neutral and balanced three-phase system |
| Current inputs | |
| Rated current Ie | 1A~ or 5A~ |
| Measuring range | for 1A scale: 0,025 - 1,2A~ for 5A scale: 0,025 - 6A~ |
| Type of input | Shunt supplied by an external current transformer (low voltage). Max. 5A |
| Measuring method | True RMS |
| Overload capacity | +20% Ie |
| Overload peak | 50A for 1 second |
| Power consumption | <0.6VA |
| Measuring accuracy | |
| Line voltage | ±0.5% f.s. ±1digit |
| Relay outputs OUT 1 - 7 | |
| Number and type of contact | 7 each with 1 NO + contact common |
| Maximum rated voltage | 415V~ |
| Rated current | 5A 250V~ AC1 / 1.5A 415V~ AC15 |
| UL Rating | B300; 5A 250V~ |
| Maximum current at contact common | 10A |
| Relay output OUT 8 | |
| Number and type of contact | 1 changeover |
| Maximum rated voltage | 415V~ |
| Rated current | 5A 250V~ AC1 / 1.5A 415V~ AC15 |
| UL Rating | B300; 5A 250V~ |

| Calendar-clock (Real time clock-RTC) | |
|---|---|
| Reserve energy | Backup capacitor |
| Operating time without supply voltage | About 12...15 days |
| Insulation | |
| Rated insulation voltage Ui | 600V~ |
| Rated impulse withstand voltage Uimp | 9.5kV |
| Power frequency withstand voltage | 5.2kV |
| Ambient conditions | |
| Operating temperature | -20 to +70°C |
| Storage temperature | -30 to +80°C |
| Relative humidity | <80% (IEC/EN/BS 60068-2-78) |
| Maximum pollution degree | 2 |
| Overvoltage category | 3 |
| Measurement category | III |
| Climatic sequence | Z/ABDM (IEC/EN/BS 60068-2-61) |
| Shock resistance | 15g (IEC/EN/BS 60068-2-27) |
| Vibration resistance | 0.7g (IEC/EN/BS 60068-2-6) |
| Connections | |
| Type of terminal | Plug-in / removable |
| Conductor cross section (min-max) | 0.2-2.5 mm ² (24-12 AWG) |
| Conductor cross section (min-max) per UL | 0.75-2.5 mm ² (18-12 AWG) |
| Tightening torque | 0.56 Nm (5 lbin / 4.5 lbin per UL) |
| Housing | |
| Version | Flush mount |
| Material | Polycarbonate |
| Degree of protection | IP65 on front; IP20 terminals |
| Weight | 980g |
| Certifications and compliance | |
| Certifications obtained | cULus, EAC, RCM |
| UL Marking | Use 60°C/75°C copper (CU) conductor only AWG Range: 18 - 12 AWG stranded or solid Field Wiring Terminals Tightening Torque: 4.5lb.in Flat panel mounting on a Type 1 enclosure |
| Comply with standards | IEC/EN/BS 61010-1, IEC/EN/BS 61000-6-2 IEC/EN/BS 61000-6-3, UL508, CSA C22.2 n°14 |

^① Auxiliary supply connected to a line with a phase-neutral voltage ≤300V.