

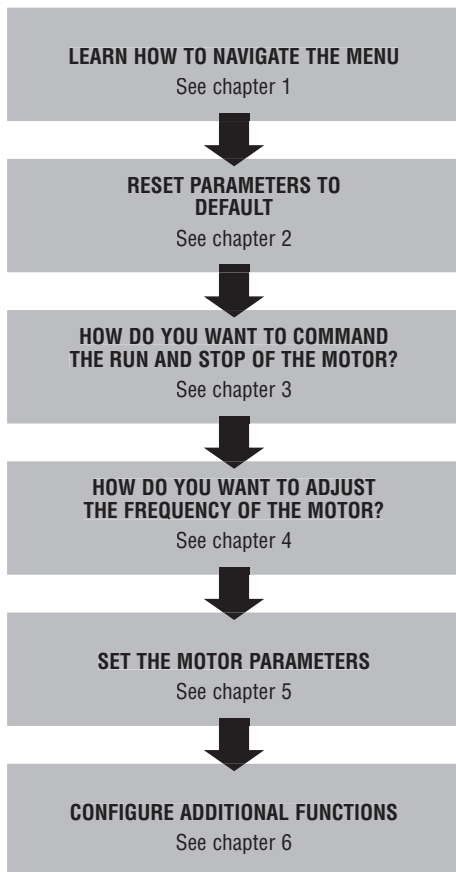

Steps to follow for the configuration of the variable speed drive:



SUMMARY

	PAGE
1. Navigation in the menu	2
2. Reset parameters to default	3
3. Command the run/stop of the motor	4
3.1 2-wires control from the flexible I/O terminal block	4
3.2 From keypad	4
4. Frequency adjustment	5
4.1 From keypad	5
4.2 From external potentiometer	5
4.3 From analog input signal type 0-10V	5
4.4 From analog input signal type 4-20mA	6
4.5 With preset frequency setpoints	6
4.6 From motor potentiometer (MOP)	7
4.7 PID Control - Setpoint adjusted with keypad and feedback signal type 0-10V	7
4.8 PID Control - Setpoint adjusted with keypad and feedback signal type 4-20mA	7
5. Motor parameters	8
6. Additional functions	9
6.1 Configuration of the relay output function	9
6.2 Configuration of the DO1 digital output function	9
6.3 Configuration of the AO1 analog output function	10
6.4 Enable of the start at power-up function (auto-restart)	10
6.5 Command of digital inputs from PLC	11
6.6 Configuration of the automatic (PID) / manual (frequency regulation) mode	11
6.7 Common error codes	13

1. NAVIGATION IN THE MENU AND LOADING DEFAULT SETTINGS

Function of the keypad keys

Navigate: select group/parameter. Change parameter setting.	
Pressed shortly: enter in the sub parameter level. Keep pressed for more than 3 sec to save parameter settings in the memory.	
Exit from the menu/parameter	
Stop motor	
Run motor	
Activate full keypad control	
Reversal of rotation direction	



Example of navigation in the menu of the VSD and modification of a parameter.

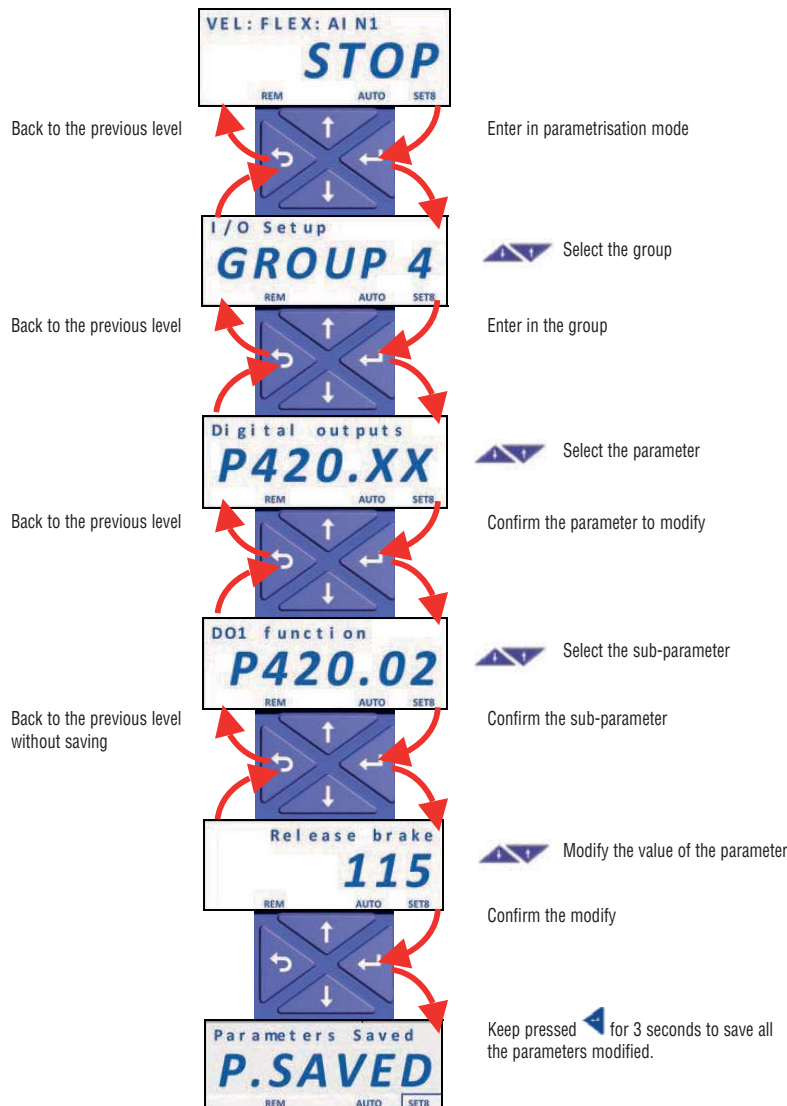

2. RESET PARAMETERS TO DEFAULT

To reset all the parameters to factory settings follow this procedure:

- Set the parameter P700.01 = 1 (load default settings)

- Press the  button several times to exit from the programming menu until it appears the text STOP.

- Keep pressed the  button for 3 seconds until it appears the text "P.SAVED", which indicates the saving of the parameters.

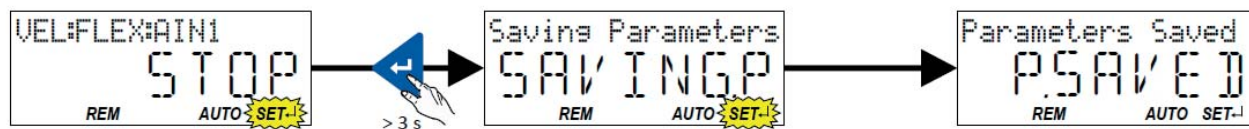

3. COMMAND THE RUN/STOP OF THE MOTOR

3.1 2-wires control from the flexible I/O terminal block

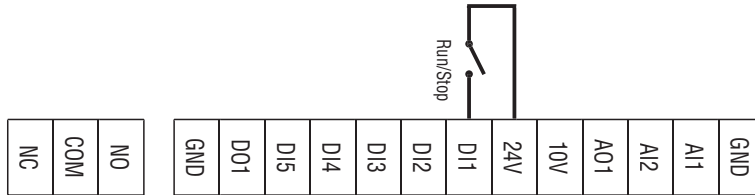

Parameter	Function	Setting	Description
P400.01	VSD enable	1	VSD always enabled (default setting)
P400.02	Run/stop command	11	Run/stop command from digital input DI1 (connected between terminals DI1-24V)

3.2 From keypad



Parameter	Function	Setting	Description
P400.01	VSD enable	1	VSD always enabled (default setting)
P400.12	Keypad control	1	Activate keypad as control source
P400.02	Run/stop command	1	Constant true (run/stop command is managed by keypad)

4. FREQUENCY ADJUSTMENT

4.1 From keypad

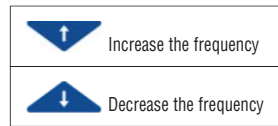

Parameter	Function	Setting	Description
P201.01	Frequency setpoint source	1	Frequency adjusted from keypad
P210.00	Minimum frequency	0Hz	Insert the value of the minimum frequency
P211.00	Maximum frequency	50Hz	Insert the value of the maximum frequency
P220.00	Acceleration time	5sec	Insert the value of the acceleration time
P221.00	Deceleration time	5sec	Insert the value of the deceleration time

4.2 From external potentiometer

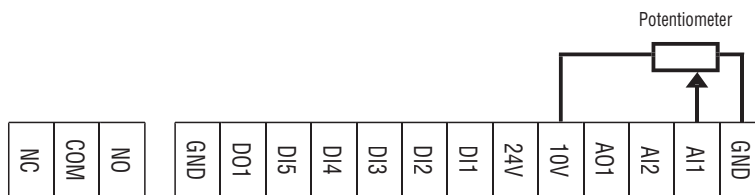

Parameter	Function	Setting	Description
P201.01	Frequency setpoint source	2	Frequency adjusted with analog input 1 (AI1)
P210.00	Minimum frequency	0Hz	Insert the value of the minimum frequency
P211.00	Maximum frequency	50Hz	Insert the value of the maximum frequency
P220.00	Acceleration time	5sec	Insert the value of the acceleration time
P221.00	Deceleration time	5sec	Insert the value of the deceleration time
P430.01	Analog input 1 (AI1) configuration	0	Analog signal type 0-10V
P430.02	Value of frequency when AI1 is at minimum	0Hz	Frequency when AI1 is at minimum (AI1 = 0V)
P430.03	Value of frequency when AI1 is at maximum	50Hz	Frequency when AI1 is at maximum (AI1 = 10V)

4.3 From analog input signal type 0-10V

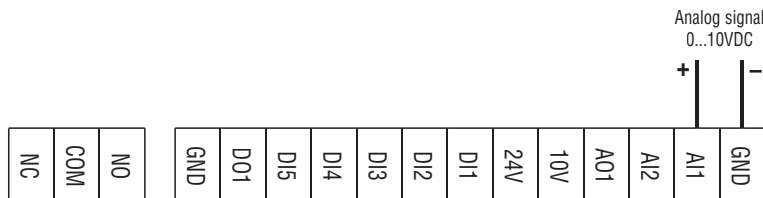

Parameter	Function	Setting	Description
P201.01	Frequency setpoint source	2	Frequency adjusted with analog input 1 (AI1)
P210.00	Minimum frequency	0Hz	Insert the value of the minimum frequency
P211.00	Maximum frequency	50Hz	Insert the value of the maximum frequency
P220.00	Acceleration time	5sec	Insert the value of the acceleration time
P221.00	Deceleration time	5sec	Insert the value of the deceleration time
P430.01	Analog input 1 (AI1) configuration	0	Analog signal type 0-10V
P430.02	Value of frequency when AI1 is at minimum	0Hz	Frequency when AI1 is at 0V
P430.03	Value of frequency when AI1 is at maximum	50Hz	Frequency when AI1 is at 10V

4.4 From analog input signal type 4-20mA

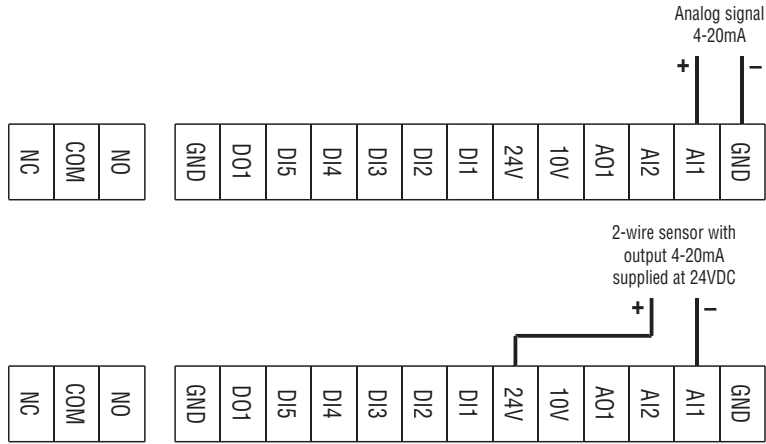

Parameter	Function	Setting	Description
P201.01	Frequency setpoint source	2	Frequency adjusted with analog input 1 (A1)
P210.00	Minimum frequency	0Hz	Insert the value of the minimum frequency
P211.00	Maximum frequency	50Hz	Insert the value of the maximum frequency
P220.00	Acceleration time	5sec	Insert the value of the acceleration time
P221.00	Deceleration time	5sec	Insert the value of the deceleration time
P430.01	Analog input 1 (A1) configuration	4	Analog signal type 4-20mA
P430.02	Value of frequency when A11 is at minimum	0Hz	Frequency when A11 is at 4mA
P430.03	Value of frequency when A11 is at maximum	50Hz	Frequency when A11 is at 20mA

4.5 With preset frequency setpoints

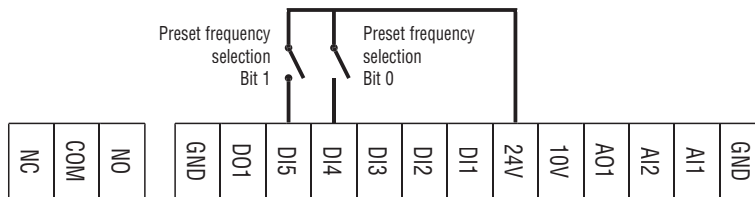

D15 (bit 0)	D14 (bit 1)	Preset frequency activated
Open	Open	No preset frequency activated. The frequency is adjusted by the source set in P201.01
Open	Closed	Preset frequency 1
Closed	Open	Preset frequency 2
Closed	Closed	Preset frequency 3

Selection table of preset frequencies.

Parameter	Function	Setting	Description
P210.00	Minimum frequency	0Hz	Insert the value of the minimum frequency
P211.00	Maximum frequency	50Hz	Insert the value of the maximum frequency
P220.00	Acceleration time	5sec	Insert the value of the acceleration time
P221.00	Deceleration time	5sec	Insert the value of the deceleration time
P400.18	Preset frequency selection bit 0	14	D14 is the bit 0 of preset frequency selection
P400.19	Preset frequency selection bit 1	15	D15 is the bit 1 of preset frequency selection
P450.01	Preset frequency 1	20Hz	Value of preset frequency 1 (D14 closed)
P450.02	Preset frequency 2	45Hz	Value of preset frequency 2 (D15 closed)
P450.03	Preset frequency 3	50Hz	Value of preset frequency 3 (D14 and D15 closed)

4.6 From motor potentiometer (MOP)

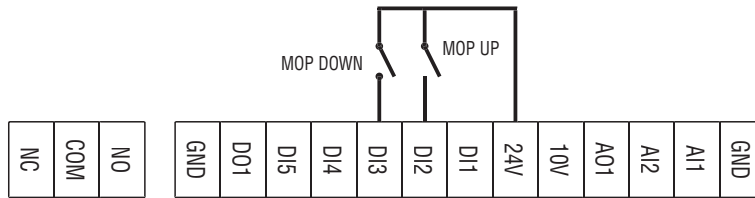

If the motor potentiometer is active as setpoint source, the frequency setpoint can be changed via the triggers assigned to two input contacts configured with the functions "MOP UP" (increase frequency) and "MOP DOWN" (decrease frequency).

Parameter	Function	Setting	Description
P400.04	Reset fault function (default: DI2)	0	Disable the reset fault function
P400.13	Reverse rotation function (default: DI3)	0	Disable the reverse rotation function
P400.23	Motor potentiometr UP function	12	DI2 = MOP UP function
P400.24	Motor potentiometr DOWN function	13	DI3 = MOP DOWN function
P400.25	Enable motor potentiometer as setpoint	1	MOP is used as frequency setpoint
P413.00	Motor potentiometr starting mode	0	The last MOP value is used as initial value

4.7 PID Control - Setpoint adjusted with keypad and feedback signal type 0-10V

Parameter	Function	Setting	Description
P201.02	PID setpoint source	1	PID setpoint adjusted from keypad
P210.00	Minimum frequency	30Hz	Insert the value of the minimum frequency
P211.00	Maximum frequency	50Hz	Insert the value of the maximum frequency
P220.00	Acceleration time	5sec	Insert the value of the acceleration time
P221.00	Deceleration time	5sec	Insert the value of the deceleration time
P430.01	Analog input 1 (AI1) configuration	0	Analog signal type 0-10V
P600.01	PID enable	1	PID function enabled
P600.02	PID feedback source	1	PID feedback connected to analog input AI1
P610.01	PID sleep mode activation	1	PID sleep mode enabled. Sleep mode is activated when the frequency is less than P610.03 for a time longer than P610.05
P610.03	PID sleep mode: frequency treshold	35Hz	See above
P610.05	PID sleep mode: delay time	5sec	See above

4.8 PID Control - Setpoint adjusted with keypad and feedback signal type 4-20mA

Parameter	Function	Setting	Description
P201.02	PID setpoint source	1	PID setpoint adjusted from keypad
P210.00	Minimum frequency	30Hz	Insert the value of the minimum frequency
P211.00	Maximum frequency	50Hz	Insert the value of the maximum frequency
P220.00	Acceleration time	5sec	Insert the value of the acceleration time
P221.00	Deceleration time	5sec	Insert the value of the deceleration time
P430.01	Analog input 1 (AI1) configuration	4	Analog signal type 4-20mA
P600.01	PID enable	1	PID function enabled
P600.02	PID feedback source	1	PID feedback connected to analog input AI1
P610.01	PID sleep mode activation	1	PID sleep mode enabled. Sleep mode is activated when the frequency is less than P610.03 for a time longer than P610.05
P610.03	PID sleep mode: frequency treshold	35Hz	See above
P610.05	PID sleep mode: delay time	5sec	See above

5. MOTOR PARAMETERS

1586 GB 01 19

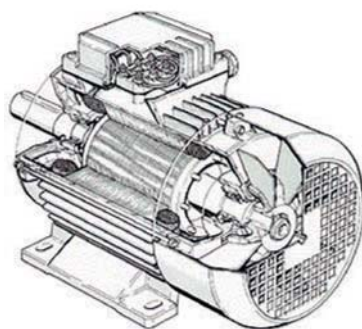

Parameter	Function	Setting	Description
P208.01	AC input voltage	0 (=230V)	Insert the value of the supply voltage
P300.00	Motor control mode	6	V/f characteristic control, open loop
P302.00	V/f shape	0	Linear V/f (Applications: conveyor belts, ...)
		1	Quadratic V/f (Applications: pumps, fans, ...)
P303.01	V/f Base voltage	230V	Set the same value of the rated voltage of the motor (P320.07)
P303.02	V/f Base frequency	50Hz	Set the same value of the rated frequency of the motor (P320.05)
P315.01	Slip compensation	5%	Set the suggested value
P320.04	Rated speed of the motor	__rpm	Insert the rated speed of the motor
P320.05	Rated frequency of the motor	__Hz	Set the rated frequency of the motor
P320.06	Rated power of the motor	__KW	Set the rated power of the motor
P320.07	Rated voltage of the motor	__V	Set the rated voltage of the motor
P320.08	Rated cosphi of the motor	__	Set the rated cosphi of the motor
P323.00	Rated current of the motor	__A	Insert the rated current of the motor. Setting this parameter, the motor thermic protection will be enabled.

NOTE. If you need to enable the sensorless vector control set P300.00=4.

All the other parameters must be left to default settings

Automatic motor data identification

Following the settings of the rated motor parameters, the automatic identification of the motor data can be performed, which results in the best possible parameter settings.

Preconditions

- The motor must be cold.
- All rated motor data are known and set in the VLA1 (see above table).
- The VLA1 is supplied (DC-bus voltage is available).
- The VLA1 is enabled, error-free and in the "Ready to switch on" or "Switched on" device state.
- The motor is stopped (no start enable).
- No quick stop is active.

Procedure

- Enable the automatic motor data identification: Set P327.04 = 1.
- Issue the start command to start the procedure.

Parameter	Function	Setting	Description
P327.04	Automatic motor data identification	1	1= Start automatic identification of the motor data. Note. During the procedure, the motor is energized!

As soon as the process has been started, the VLA1 characteristic and the motor equivalent circuit diagram data are automatically identified.

The procedure can take from some seconds to minutes. During and after the procedure, the LED "RDY" (blue) is permanently on. After completing, a renewed start command is required to start the motor.

6. ADDITIONAL FUNCTIONS

6.1 Configuration of the relay output function

To configure the function of the relay output with changeover contact (terminals NO-COM-NC) is necessary to set the parameter P420.01.

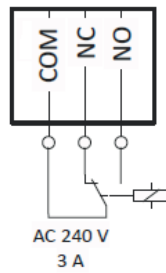

Here below are listed the most common functions.

Parameter	Function	Setting	Description
P420.01	Relay output function	50	Function "running": the relay switches when the output frequency of the VLA1 is greater than 0.2Hz.
		56	Function "error active": the relay switches in case of active error.
		70	Function "frequency threshold exceeded": the relay switches when the output frequency of the VLA1 is greater than the threshold set in P412.00.
		78	Function "current limit reached": the relay switches when the motor current is greater or equal to the maximum threshold set in P324.00 (calculated as % of the motor rated current P323.00).

6.2 Configuration of the DO1 digital output function

To configure the function of the digital output (terminals DO1-GND) is necessary to set the parameter P420.02.

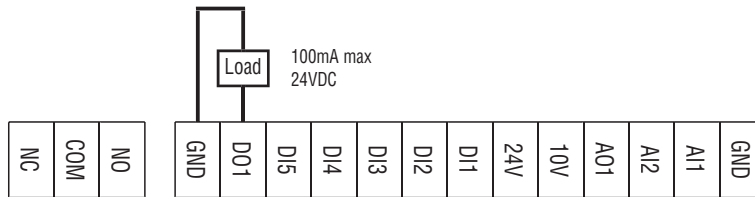

Here below are listed the most common functions.

Parameter	Function	Setting	Description
P420.02	DO1 digital output function	50	Function "running": the DO1 output is activated when the output frequency of the VLA1 is greater than 0.2Hz.
		56	Function "error active": the DO1 output is activated in case of active error.
		70	Function "frequency threshold exceeded": the DO1 output is activated when the output frequency of the VLA1 is greater than the threshold set in P412.00.
		78	Function "current limit reached": the DO1 output is activated when the motor current is greater or equal to the maximum threshold set in P324.00 (calculated as % of the motor rated current P323.00).

6.3 Configuration of the AO1 analog output function

To configure the function of the AO1 analog output (terminals AO1-GND) is necessary to set the following parameters.

Parameter	Function	Setting	Description
P440.01	AO1 analog output range	1	0...10VDC
		2	0...5VDC
		3	2...10VDC
		4	4...20mA
		5	0...20mA
P440.02	AO1 analog output function	1	Actual output frequency (resolution 0.1 Hz)
		2	Actual frequency setpoint (resolution 0.1 Hz)
		3	Input signal of analog input 1 (resolution 0.1 %)
		4	Input signal of analog input 2 (resolution 0.1 %)
		5	Actual motor current (resolution 0.1 A)
		6	Actual output power (resolution 0.001 kW)
		7	Actual torque value (resolution 0.1 %)
P440.03	Definition of the signal value that corresponds to the minimum value at AO1 analog output.	0	Example: if the analog output is configured with range 4...20mA (P440.01=4), P440.03 is the value of the signal which corresponds to AO1=4mA.
P440.04	Definition of the signal value that corresponds to the maximum value at AO1 analog output.	1000	Example: if the analog output is configured with range 4...20mA (P440.01=4), P440.04 is the value of the signal which corresponds to AO1=20mA.

Example: configure the AO1 analog output with range 0...10VDC correspondent to the output frequency range 0...50Hz.

Parameter	Function	Setting	Description
P440.01	AO1 analog output range	1	0...10VDC
P440.02	AO1 analog output function	1	Actual output frequency (resolution 0.1 Hz)
P440.03	Definition of the signal value that corresponds to the minimum value at AO1 analog output.	0	The AO1 will be 0V when the output frequency is 0.0Hz.
P440.04	Definition of the signal value that corresponds to the maximum value at AO1 analog output.	500	The AO1 will be 10V when the output frequency is 50.0Hz.

6.4 Enable of the start at power-up function (auto-restart)

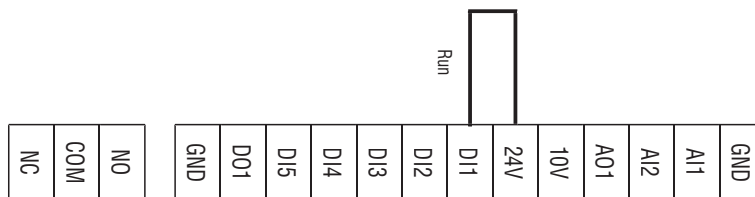

Parameter	Function	Setting	Description
P203.02	Start at power-up enable (AUTOSTART)	1	The motor is automatically started after switching on the mains voltage of VLA1. Requirements: - The VLA1 must be enabled. - The "Run" function (P400.02) must be associated to a digital input DI and it must be maintained closed to allow the automatic restart of the motor at the power on.
P200.00	Control selection	0	The run/stop command are managed by flexible I/O.
P400.02	Run/stop command	11	Run/stop command from digital input DI1.

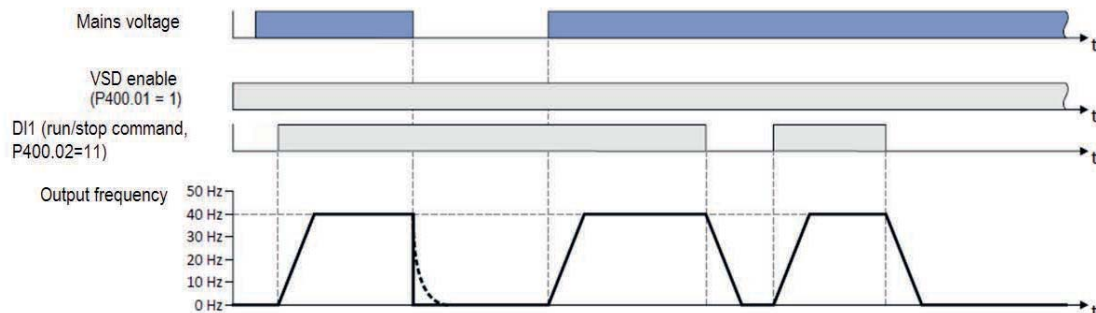

Warning! The activation of this mode causes the automatic restart of the motor at the switching on of the mains voltage of VLA1 variable speed drive. Verify that all the safety requirements are met.

6.5 Command of digital inputs from PLC

1586 GB 01 19

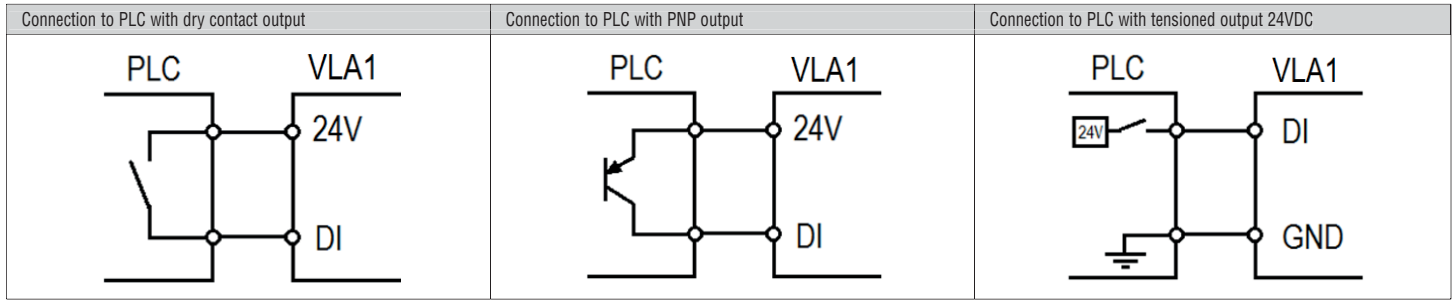

6.6 Configuration of the automatic (PID) / manual (frequency regulation) mode

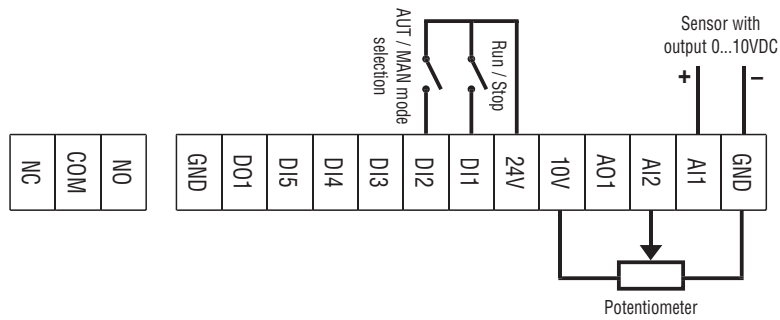

The purpose of this configuration is to manage with a digital input the switching between two operating mode:

- Automatic mode (AUT): the variable speed drive works with an automatic PID control
- Manual mode (MAN): the variable speed drive is manually regulated in frequency .

In this example are used the following digital inputs:

Digital input	Function
DI1	Command of the run/stop, independently from the selected mode (AUT/MAN).
DI2	Command the switching between the AUT and MAN mode: opened = AUT mode, closed = MAN mode.

Automatic mode (AUT)

In AUT mode the variable speed drive works with PID control, where the PID setpoint is set from keypad and the feedback is monitored from the AI1 analog input.

In this example we have assumed that on the AI1 analog input is connected a pressure sensor with output 0-10V, correspondent to a pressure of 0-15Bar with a linear characteristic, as shown in the following diagram.

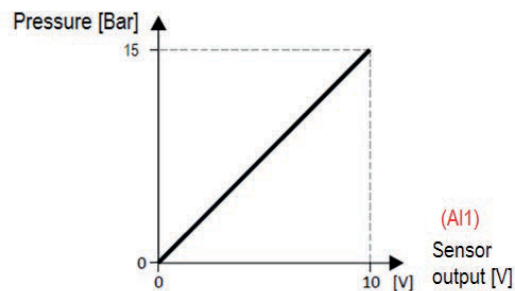

This means that: if the output of the sensor is 0V it means a pressure of 0 Bar, if the output of the sensor is 10V it means a pressure of 15 Bar, if the output of the sensor is 5V it means a pressure of 7.5 Bar, and so on.

In addition, in this example we want to allow the user of the VLA1 to set a PID setpoint limited from 2 Bar to 8 Bar.

Manual mode (MAN)

In MAN mode the PID control is de-activated and the variable speed drive works with manual regulation of the frequency setpoint via a potentiometer connected to the AI2 analog input (type 0-10V).

In this example we configure the variable speed drive to provide an output frequency of 0Hz when the potentiometer is at minimum of its regulation scale (0V) and a frequency of 50Hz when the potentiometer is at maximum (10V).

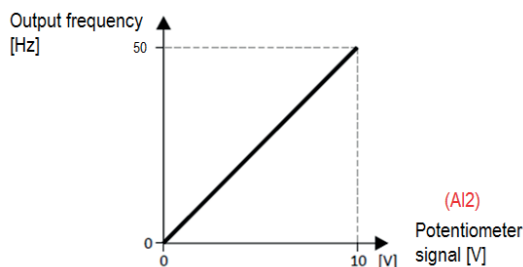

Parameter	Function	Setting	Description
P201.01	Frequency setpoint source	3	Frequency adjusted with analog input 2 (AI2)
P201.02	PID setpoint source	1	PID setpoint adjusted from keypad
P210.00	Minimum frequency	0 Hz	Insert the value of the minimum frequency
P211.00	Maximum frequency	50 Hz	Insert the value of the maximum frequency
P220.00	Acceleration time	5 sec	Insert the value of the acceleration time
P221.00	Deceleration time	5 sec	Insert the value of the deceleration time
I/O configuration (AI1 = PID feedback, AI2 = frequency setpoint, DI1 = run/stop, DI2 = AUT-MAN mode switch)			
P430.01	Analog input 1 (AI1) configuration	0	Analog signal type 0-10V
P430.04	PID value when AI1 is at minimum	0	Minimum value of AI1 signal expressed in PID Unit (0V = 0 PID unit, in this example correspondent to 0 Bar of pressure)
P430.05	PID value when AI1 is at maximum	15	Maximum value of AI1 signal expressed in PID Unit (10V = 15 PID unit, in this example correspondent to 15 Bar of pressure)
P431.01	Analog input 2 (AI2) configuration	0	Analog signal type 0-10V
P431.02	Frequency value when AI2 is at minimum	0 Hz	Insert the frequency value correspondent to AI2 signal at minimum (0V)
P431.03	Frequency value when AI2 is at maximum	50 Hz	Insert the frequency value correspondent to AI2 signal at maximum (10V)
P400.02	Run/stop command	11	Run/stop command from digital input DI1
P400.45	Deactivate PID control	12	DI2 opened = PID enabled, provided that P600.01=1 (AUT mode) DI2 closed = PID disabled (MAN mode)
Configuration of PID parameters (AUT mode)			
P600.01	PID enable	1	PID function enabled
P600.02	PID feedback source	1	PID feedback connected to analog input AI1
P600.05	Minimum PID operating frequency	20%	Minimum value of the operating frequency of the PID control expressed as % of the maximum frequency of the drive P211.00 (100% = P211.00 = 50Hz) In this example: 20% of 50Hz = 10Hz
P600.06	Maximum PID operating frequency	80%	Maximum value of the operating frequency of the PID control expressed as % of the maximum frequency of the drive P211.00 (100% = P211.00 = 50Hz) In this example: 80% of 50Hz = 40Hz
P605.01	Minimum value of the PID setpoint	2	Minimum value of the settable PID setpoint, expressed in PID unit. In this example: 2 PID Unit, correspondent to 2 Bar of pressure.
P605.02	Maximum value of the PID setpoint	8	Maximum value of the settable PID setpoint, expressed in PID unit. In this example: 8 PID Unit, correspondent to 8 Bar of pressure.
P606.01	PID acceleration time	10 sec	Insert the acceleration time of the PID control
P606.02	PID deceleration time	10 sec	Insert the deceleration time of the PID control

Example of use.

Once the parameters listed above have been set on the VLA1, test the functioning:

- Keep opened the DI2 digital input to allow the enable of the automatic mode (AUT).



- With the  buttons of the keypad set a PID setpoint, which for this specific example it corresponds to a pressure setpoint. For example, set a PID setpoint of 4.0 PID Unit (= 4 Bar).
- The VLA1 read the value of the pressure of the plant (PID feedback) from the AI1 analog input, to which is connected the output of a pressure sensor. The 0- 10V voltage signal of the pressure sensor is automatically transformed by the VLA1 in a pressure value according to the parameters previously set (in this example: 0V = 0 Bar, 10V = 15 Bar).
- Close the DI1 digital input to run the motor.
- If the pressure of the plant is lower than the setpoint (e.g. 2 Bar, which is lower than 4 Bar) the VLA1 increases the speed of the motor by regulating the output frequency until the PID setpoint is reached. In this specific example, the output frequency of the drive when PID control is active is limited to the 20% and 80% of the maximum frequency (50Hz), which means from 10Hz to 40Hz.
- If you want to switch the operating mode to manual mode (MAN) close the DI2 digital input.
- Now the PID control is de-activated (the value of AI1 signal is ignored). The output frequency of the drive is adjusted with the external potentiometer, connected to the AI2 analog input. In this specific example, the output frequency regulated with the potentiometer can be adjusted from 0Hz to 50Hz.
- To command the motor stop, open the DI1 digital input.

6.8 Common error codes

Error code	Description	Possible causes	Remedy
0x2350	Motor overload ($i^2 \cdot t$)	Motor thermally overloaded. Possible causes: <ul style="list-style-type: none"> – Impermissible continuous current. – Too frequent acceleration processes. – Too long acceleration processes. 	<ul style="list-style-type: none"> – Check drive dimensioning. – Check machine/driven mechanics for excessive load.
0x2320	Short circuit/earth leakage	<ul style="list-style-type: none"> – Short circuit/earth fault of motor cable – Capacitive charging current of the motor cable too high. 	<ul style="list-style-type: none"> – Check motor cable. – Check length of the motor cable. – Use shorter or lower-capacitance motor cable.
0x2382	I*t error	Device utilisation (I*t) too high by frequent and too long acceleration processes.	<ul style="list-style-type: none"> – Check drive dimensioning.
0x3210	DC bus overvoltage	DC-bus voltage has exceeded the error threshold for overvoltage (display in parameter P208.06, results from the setting of the rated mains voltage in P208.01). Possible causes: <ul style="list-style-type: none"> – Too high braking energy. – Too high mains voltage. 	<ul style="list-style-type: none"> – Reduce dynamic performance of the load profile. – Check mains voltage. – Check settings for the brake energy management (see chapter Brake energy management on I585 instruction).
0x3220	DC bus undervoltage	DC-bus voltage has fallen below the error threshold for undervoltage (display in parameter P208.03, results from the setting of the rated mains voltage in P208.01).	<ul style="list-style-type: none"> – Check mains voltage. – Check DC-bus voltage. – Check mains settings (see P208.01).
0x4210	Power unit overtemperature	The heatsink temperature of the power unit (display in P117.01) has exceeded the fixed error threshold 100°C. Possible causes: <ul style="list-style-type: none"> – Ambient temperature too high. – Fan or ventilation slots are polluted. – Fan is defective. 	<ul style="list-style-type: none"> – Provide for a sufficient cooling of the device. – Clean fan and ventilation slots. – If required, replace fan. – Reduce switching frequency in P305.00.

I586 GB 01 19